



PACIFIC
WHOLESALE DISTRIBUTORS

Custom Made Shutter Manual Internal Applications

TIMBER
eco



November 2024

Version 2024.1

Copyright © Pacific Wholesale Distributors 2008.

Unauthorised use and/or duplication of this material without the express written permission from the owner is strictly prohibited.

T +61 2 9680 7999

E shutterorders@pacificwholesale.com.au | **W** www.pacificwholesale.com.au



TERMS AND CONDITIONS OF TRADING

Effective: 15th August 2022

Payment Terms

Strictly net 30 days, if there is a problem with payment, please contact us.

Pacific Wholesale Distributors reserve the right to:

1. Refuse delivery to any overdue account.
2. Charge interest on overdue accounts.
3. Refuse credit.

Delivery Terms/Freight/Shipping & Handling

Sydney Metropolitan \$56.69 – Order value below \$1,000

Regional & Interstate \$85.04 – Order value below \$1,000

Orders that exceed these values will be Free Into Store (FIS).

The additional freight charges are below;

Charge Type	Details
Tail Gate <i>Delivery to a site where there is no forklift, and pallets or other heavy consignments requires the use of a tail gate/tilt lift truck</i>	\$97.00 includes up to 2 pallets \$49.00 per additional pallet thereafter
Hand/Manual Unload <i>Delivery to a site where there is no forklift, and the consignment needs to be unloaded by hand</i>	\$74.00 per pallet or large loose item
Rejected/Futile/Un-Deliverable Delivery <i>When a consignment cannot be delivered due to the receiver being unavailable or the consignment is refused by the receiver</i>	\$92.00 includes up to 2 pallets \$46.00 per additional pallet thereafter
Waiting Time	\$69.00 after the first 30 minutes
Time Slot/Delivery Time Restriction Fee <i>When a consignment requires; A date/timeslot to be booked or a specific delivery day/time window Delivery before 2:30pm</i>	\$52.00 per consignment
Over Length Surcharge – Over 3.7m Long	\$144.00 per consignment <i>Only applies when the order value is less than \$2,000 Ex GST</i>
Residential Delivery	\$114.00 per pallet or large loose item
Post Bag	\$17.01
Overnight Express Post Bag	\$28.35

GST

GST is charged on all items at a rate of 10%.

All prices quoted in this product catalogue or additional prices **do not include GST**.

Claims

1. All credit claims must be in writing, including the relevant invoice numbers.
2. Claims must be submitted within 7 days of receipt of goods.
3. Goods may not be returned for credit without prior authorisation.
4. Pacific Wholesale Distributors will only replace faulty stock and will accept no further liability.
5. All returns are subject to a 20% re-stocking fee.

Title

Property title in all goods remains with Pacific Wholesale Distributors until the goods are paid for in full.

PRICES ARE SUBJECT TO CHANGE WITHOUT NOTICE

Contents

1.	Introduction.....	7
2.	Ordering and Measuring	12
3.	Options and Specifications	14
4.	Mounting Methods - Summary	25
5.	Hinged Panels	31
6.	Fixed Panels	47
7.	Bi Fold Panels.....	51
8.	Sliding Panels.....	59
9.	Special Requirement Windows & Options	73
10.	Hardware and Extra Timbers.....	86
11.	Sales Aids	90
12.	Shutter Remake Process.....	92
13.	Care and Maintenance	93
14.	Shutter Questions & Answers	94
15.	Glossary	96
16.	Shutter Range & Mounting Methods Reference Charts	105

1. Introduction

Elegant and stylish, Shutters will add value to a home. They are energy efficient, helping to keep a house cooler in summer and warmer in winter. Shutters offer an uninterrupted view and allow complete control of light, heat, air and privacy by simply tilting the shutter blades.

Timber Eco Shutters have a superior paint or laminated finish for longevity and are easy to care for. Available in a large range of colours, stains and laminated coatings, Timber Eco Shutters will complement and enhance any interior. With a variety of blade sizes available, Timber Eco Shutters are expertly custom made to suit all window/door types, sizes and shapes. Applications include hinged, fixed, bi fold and sliding, with a large range of quality frames to choose from.

Supporting this great range are swatches and sales aids that can be used by sales people when promoting the Shutter range, please refer to [Sales Aids](#).

Timber Eco Shutters are made of the finest selection of furniture quality, internationally certified sustainable Paulownia timber*.

- Coated with High Tensile Coatings that will not peel or crack including five shades of painted White, painted Black, Stained & Lacquered and Laminate Coating.
- A great insulator; they help to keep homes cooler in summer and warmer in winter.
- Timber Eco Shutters are moisture resistant*, therefore more suitable than standard Timbers in humid climates.
- Available in 63mm, 89mm and 114mm blade sizes *

For details on Colours please refer to the [Shutter Range & Mounting Methods Reference Charts](#)



Figure 1 Flat Stile

1.1 Photo Gallery of Timber Eco Shutters

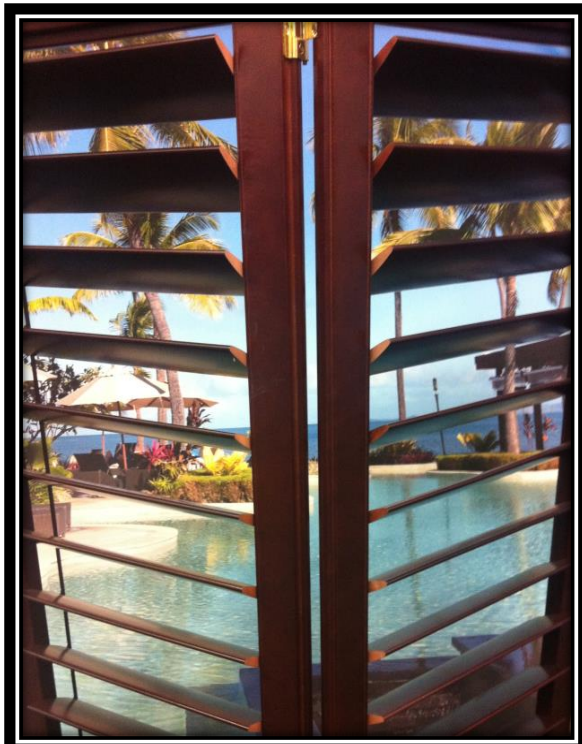

*See Glossary and Reference Charts at the end of this manual for more detailed information



*See Glossary and Reference Charts at the end of this manual for more detailed information



*See Glossary and Reference Charts at the end of this manual for more detailed information



*See Glossary and Reference Charts at the end of this manual for more detailed information

2. Ordering and Measuring

All orders **MUST** be submitted electronically in Excel by using the latest version of Pacific Wholesale's Internal Shutter Order Form.

References to the Shutter Order Form will be made throughout this manual. If you do not have the latest version of Pacific Wholesale's Shutter Order form, please contact the office shutterorders@pacificwholesale.com.au and request a copy today.

TIPS FOR FILLING OUT THE ORDER FORM

- Start from the left-hand side and work across the Order Form from left to right, as options will change according to your previous selections.
- If a cell in the order form turns yellow, this is a flag that more information is required, or that there is a problem with what has been ordered. Common issues can be:
 - Too few, or too many panels have been ordered for the width given, therefore the panels are too wide, or too narrow. Note this will not prevent an out-of-warranty size being ordered, it is a prompt only.
 - There is a Mid Rail required.
 - T Post number and positions are required.
 - The layout code given doesn't match the number of panels ordered.
 - Information is missing from the yellow cell.

Please see an example of the Pacific Wholesale Shutter Order Form on the following page.

PACIFIC WHOLESALE DISTRIBUTORS										Shutters										STORE NAME: _____		Page: 1 of 1					
PWD ORDER NO.: _____					SALES ORDER NO.: _____					CUSTOMER NAME: _____					M2		0.000										
Phone: 461 2 8550 8828					Fax: 461 2 860 7466					DELIVERY ADDRESS: _____					Panels		0										
<i>This is designed to begin at the left and work towards the right as the options will change based on the selections.</i>										<i>This is designed to begin at the left and work towards the right as the options will change based on the selections.</i>										DATE: _____		Order Requirements Alert: _____					
Mandatory Fields										Mandatory Fields										T Post Alert		Version					
Item #	Room Location	Gross Open Width	Gross Open Height	MS, In Or Out	Panel Quantity	Material & Product	Colour	Blade Size	Large Size Panel	MSI Rail Height	Window Type	Mounting Method	Layout Code	Frame Type	Left Frame	Right Frame	Top Frame	Bottom Panel/Track	Tilted Type	Hinge Colour	Sliding Open Or Closed	T Post Quantity	1st T Post	2nd T Post	3rd T Post	Plully Size	m6
1																											
2																											
3																											
4																											
5																											
6																											
7																											
8																											
9																											
10																											
11																											
12																											
13																											
14																											
15																											
Item #	Standard Special Comments #1					Standard Special Comments #2					Standard Special Comments #3					User Specific Line Item Notes/Special Comments					General Notes						
1																											
2																											
3																											
4																											
5																											
6																											
7																											
8																											
9																											
10																											
11																											
12																											
13																											
14																											
15																											
Item #	Quantity	Length	Order's		Material	Colour	Quantity	Hardware		Colour	Additional Item Notes																
1																											
2																											
3																											
4																											
5																											
6																											
7																											
8																											
9																											
10																											

*See Glossary and Reference Charts at the end of this manual for more detailed information

“Special Comments” are referred to frequently in this manual, please see below examples that can be selected when ordering:

Item #	Standard Special Comments # 1
1	
2	All Even Panels
3	Combo Panels
4	Critical Midrail
5	Left Panel Open First
6	Maximum Blades Possible
7	Panels Fixed With Light Stop Beading
8	Panels Fixed With Light Stop Beading, Front & Back
9	Panels Fixed With Magnets & Catches

Item #	Standard Special Comments # 1
1	
2	Maximum Blades Possible
3	Panels Fixed With Light Stop Beading
4	Panels Fixed With Light Stop Beading, Front & Back
5	Panels Fixed With Magnets & Catches
6	Smallest Possible Top & Bottom Rails
7	Split Tiltrod In Half
8	Split Tiltrod In Half Above Midrail
9	Split Tiltrod In Half Below Midrail

2.1 In

Recess Fit (also called Reveal Fit)

Measuring for inside reveal (recess) fit, the shutters should be measured in three places across the width and the drop and the **smallest** measurements provided. The factory will take a deduction off each side to ensure the frame can be fitted. Measurements are required to be in millimeters (mm).

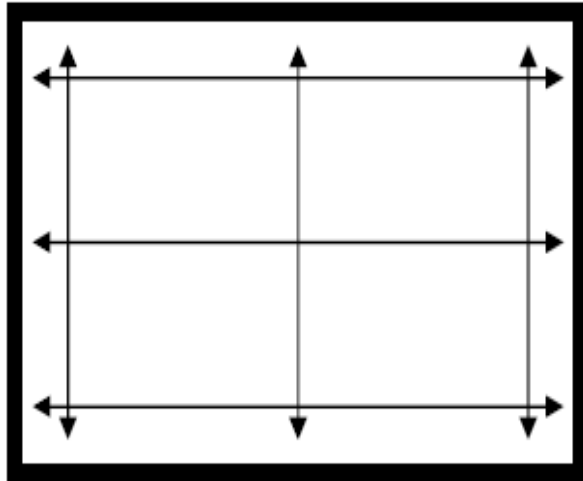

2.2 Out

Face Fit

Measuring for outside (face) fit, the opening should be measured in three places across the width and the drop and the largest measurement provided, where the outside of the shutter frame is to be installed. No deductions are taken off the outside of the frame for OUT.

If the opening has an architrave the OUT measurements are usually from the outside of the architrave, to the outside of the opposite architrave. If there is no architrave, add the width of the frame to the recess measurement to find the outside of frame measurements.

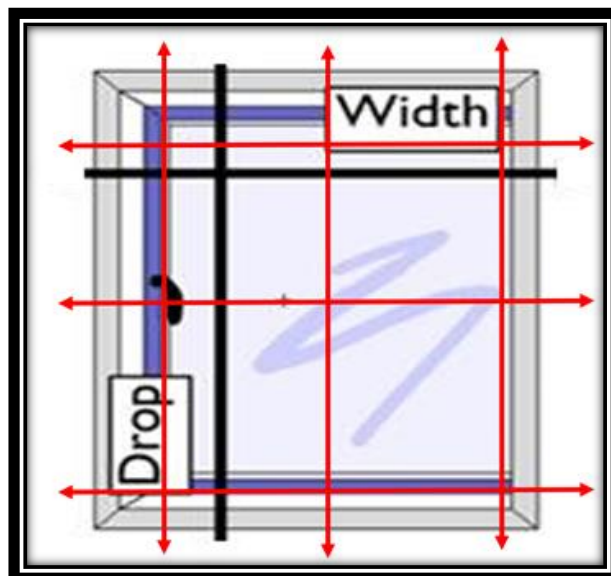

2.3 MS

Make Size

1. Is the *actual* Panel Size.
2. A MS item does not usually require frames.
3. A MS order is the size given **multiplied** by the panel quantity (unlike In and Out, where the panel quantity is divided into the width).
4. When ordering MS be aware this does not allow for any deductions for Frames or the opening / application

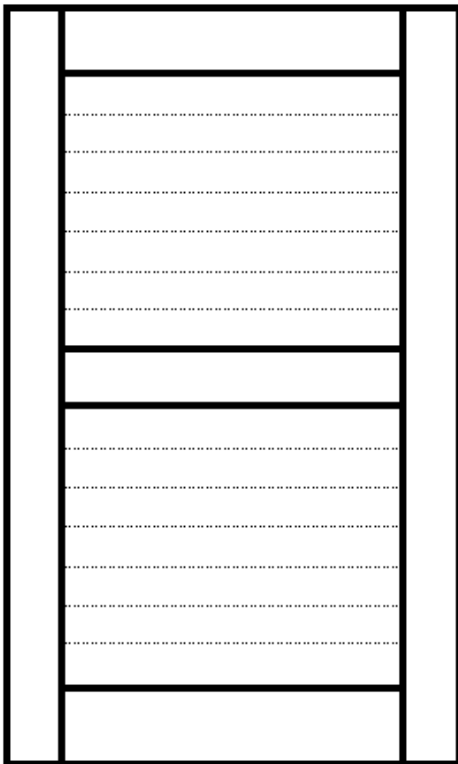

2.4 Special requirements

Please refer to Special requirements for measuring details for the following

1. Bay Windows
2. Corner Windows
3. Shaped Windows
4. Any other unusual application not covered here

3. Options and Specifications

3.1 Panel Components

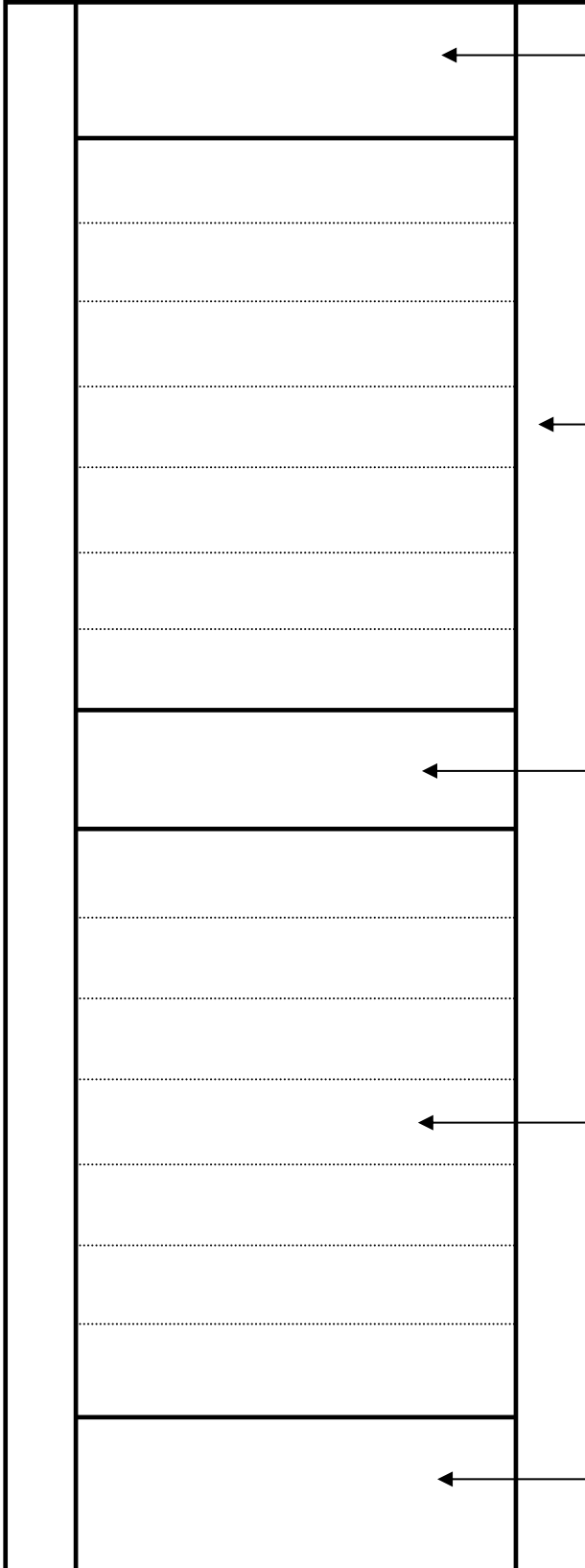

TOP & BOTTOM RAIL

These make up the top and bottom of every panel to provide strength through the panel. These differ in size depending on panel measurements.

STILES

These make up the sides of every panel. They come as either a standard stile, rabbet stile or an Astragal (D mould) stile.

MID RAIL

Mid Rails provide structural support for the panel and are required for panels over certain heights, if a customer specifically requests one, or if required to cover a mullion to allow the blades depth to operate.

LOUVRE BLADES

The horizontal slats within the panel which are available in a variety of sizes and types.

TOP & BOTTOM RAIL

These make up the top and bottom of every panel to provide strength through the panel. These differ in size depending on panel measurements.

3.2 Standard Panel Dimensions

Please refer to the Shutter Range Reference Chart on [Shutter Range & Mounting Methods Reference Charts](#) for Panel Dimensions – heights and widths are dependent on Mounting Methods.

3.3 Timber Eco Finishes

Painted Finishes

All paint finish Timber Eco Shutters are painted with a **lead free** polyurethane base coat. The coating process consists of five individual coats, hand sanded between each coat. This finish has been tested in Australian conditions.

Custom Colours

In addition to a range of fashionable standard colours, Custom Colours are available to be matched to any current Dulux paint colour. Please include the colour name and number in the General Comments section of the order form to select a Custom Colour* (surcharges apply).

Stained - Timber Grain

Our 'Stained' colours have been tested to Australian conditions and will enhance any décor with stunning results.

Laminated Coatings

Our newly designed laminate coated Timber Shutters are available in 4, on trend colours that will enhance any décor. Comprising our ever-popular Paulownia timber with a unique PVC coated layer, this product will create a real point of difference to your existing range.

For details on Colours please refer to the [Shutter Range & Mounting Methods Reference Charts](#)

3.4 Timber Eco Blades

Timber Elliptical Blade, for panels up to 950mm

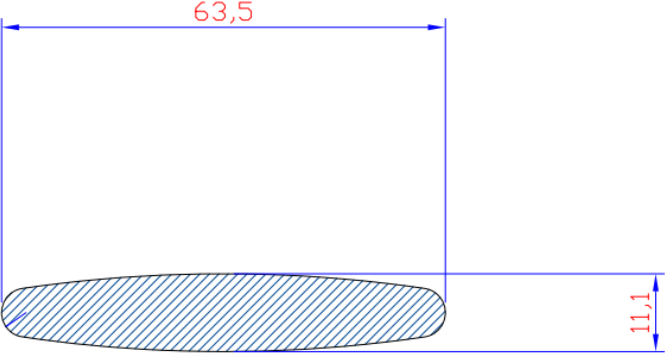
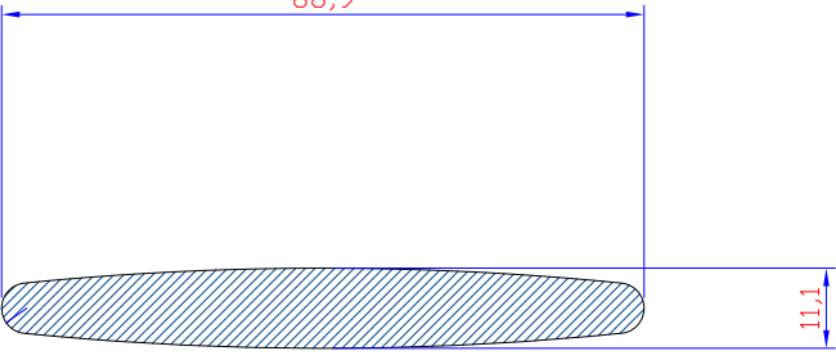
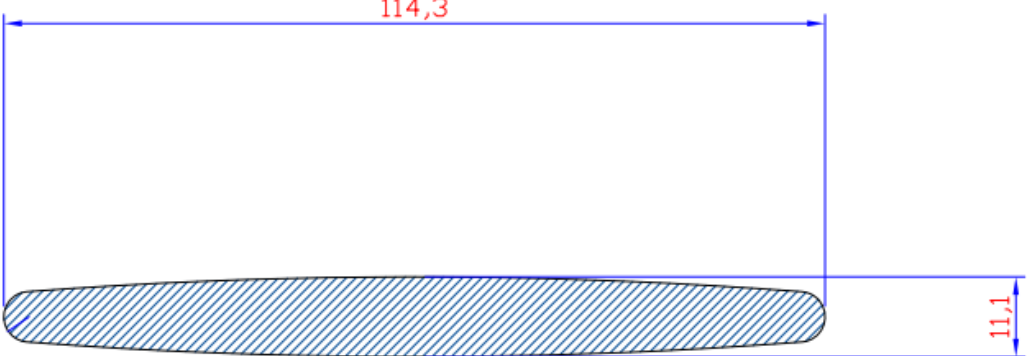
63mm	
89mm	
114mm	

3.5 Top and Bottom Rail (maximum size)

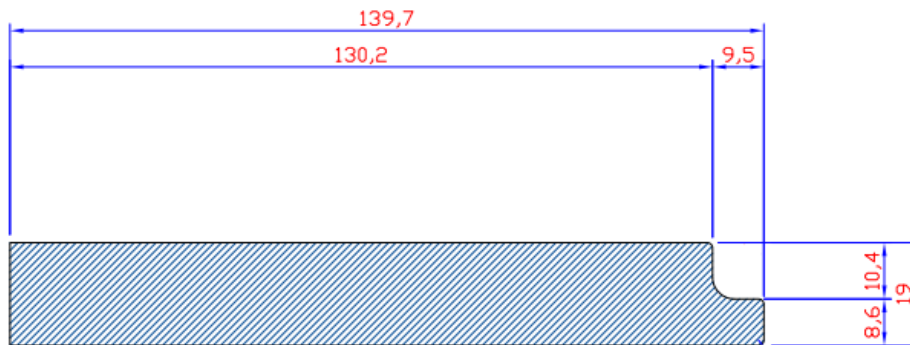

3.6 Mid Rail

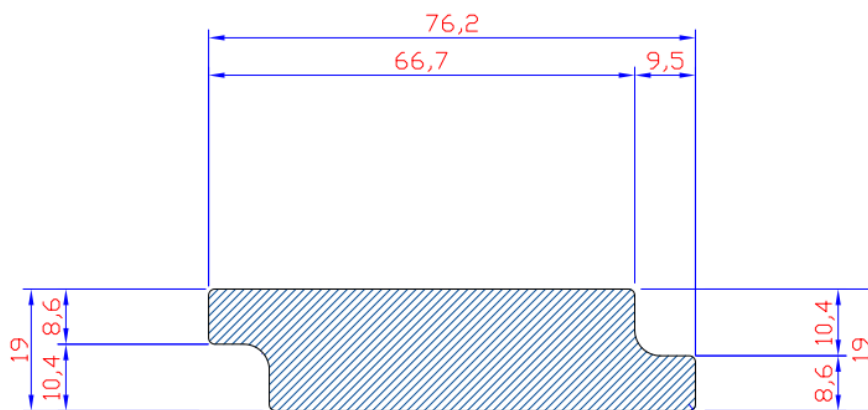

Please Note:

A Mid Rail is required on panels over 1800mm. The Mid Rail location must be measured from the bottom of the opening to the **centre** of where the mid rail is required*.

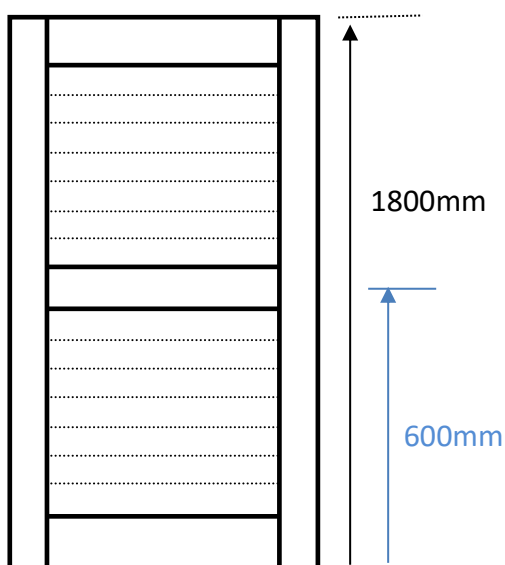

Example (see arrows):

- Gross Open Height 1800mm
- Mid rail @ 600mm (Bottom of Opening to Centre of Mid Rail)

*See Glossary and Reference Charts at the end of this manual for more detailed information

3.7 Stiles

Standard Stile

A standard shutter panel is made using a standard rectangular stile. These are available Beaded (which is the default), or Flat (no bead). This needs to be specified on the order form if default stile is not required.

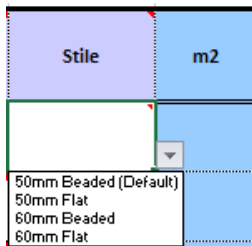

Standard Stiles are used on the side of panels butting into Frame, T Posts, or if panels only are ordered without specific instructions.

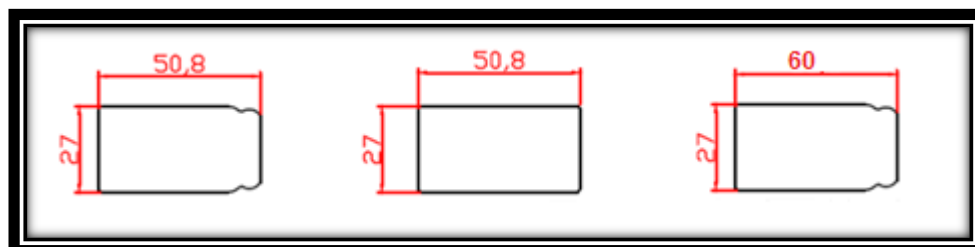

Beaded Stile (Default)

Flat Stile (Optional)

60mm Stile
(beaded)

Rabbit Stiles

Available in Beaded (Default) or Flat Stile (Optional)

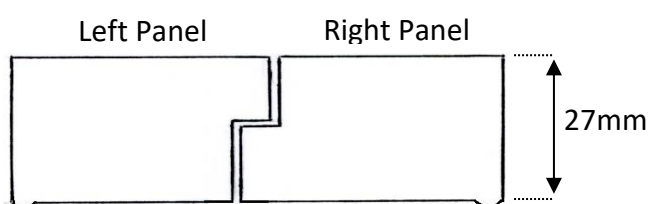

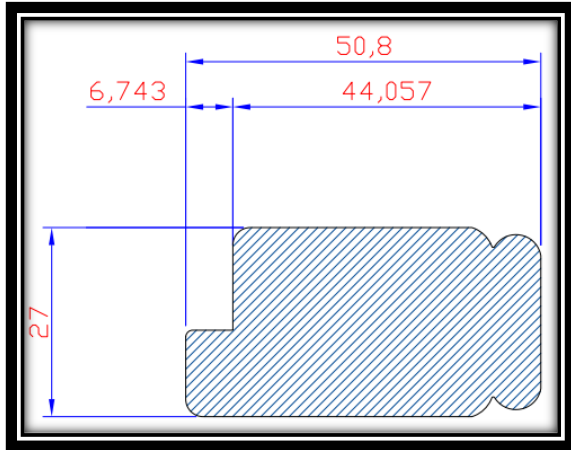

Beaded Stile (Default)

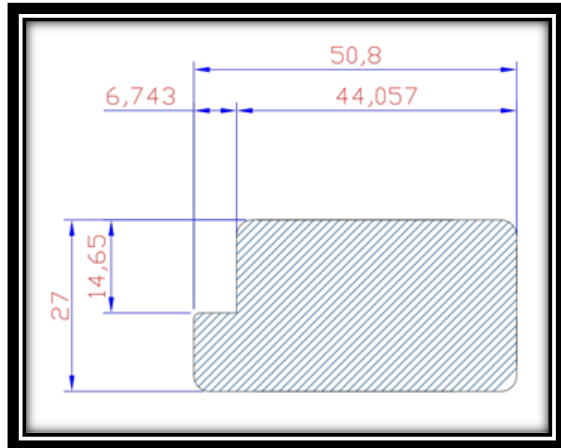

Flat Stile (Optional)

Rabbit Stiles are *our default*, used to provide light block where two panels hinged Left and Right meet. Where two panels meet in the centre, the rabbit will be back, front as shown in the drawing and photo above, unless instructed otherwise on the order form*. This means that the right-hand panel will have to be opened first. Use Standard Special Comments, or Special Comments to specify other than Right Panel opening first.

Standard Special Comments # 3	User Specific Line Item Notes/Special Comments
Left Panel Open First	
	Panel 2 and 3 to Open First Please
Left Panel Open First	
Left Panel Open First	
Maximum Blades Possible	
Panels Fixed With Light Stop Beading	
Panels Fixed With Light Stop Beading, Front & Back	
Panels Fixed With Magnets & Catches	
Smallest Possible Top & Bottom Rails	
Split Tiltrod In Half	
Split Tiltrod In Half Above Midrail	

Rabbit Stiles are often used when panels are hinged to each other, using step hinges, for Bi-Fold, Double Hinged and Sliding Combo Panel shutter situations.

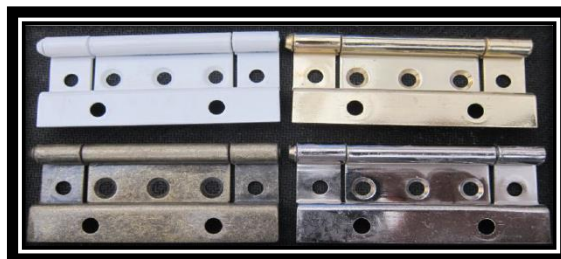

Astragal Stiles (D Mould)

Available in Beaded Stile (default) or Flat Stile, Astragal Stiles can be ordered when preferred, by specifying the location clearly in the Layout Code using a "D" and dash:

Example 1: L-DR

(D mould will be on Left Side of Right Panel)

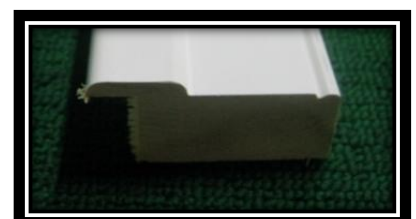

*See Glossary and Reference Charts at the end of this manual for more detailed information

Example 2: LD-R (D mould will be on Right Side of Left Panel)

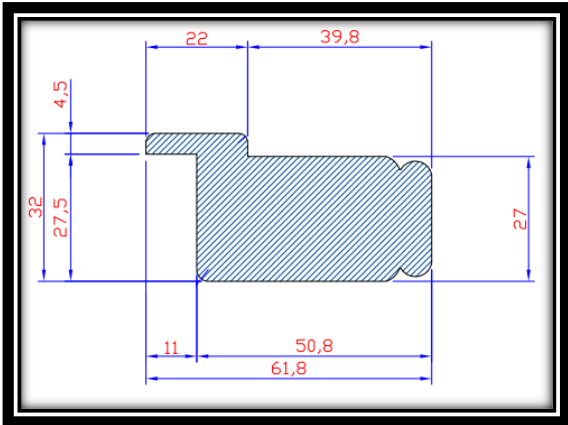

D-Mould Stile (Beaded)

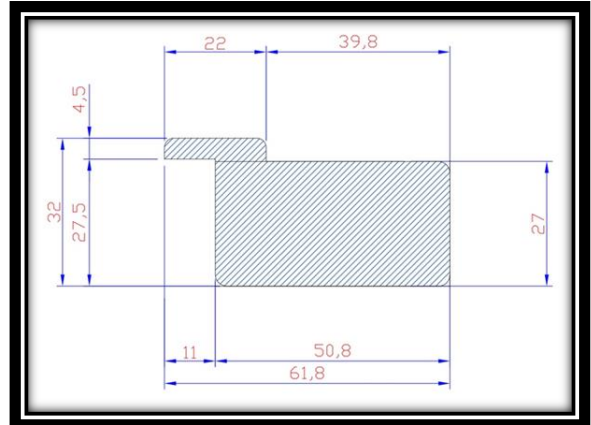

D-Mould Stile (Flat)



3.8 Tilt Rod

Four Tilt Rod Options:

1. **Hidden Tilt Rod**

Placed on the back of the panel, this sleek Aluminium Tilt Rod links the blades and is barely visible from the front. The stile is rebated to accommodate the colour co-ordinated hidden aluminium strip, on the back of the hinged side of the panel. This option provides an unobtrusive view through the shutters once the blades are open. The Hidden Tiltrod is made of Aluminium and the Tiltrod Screws are made in a 304 Grade Stainless.

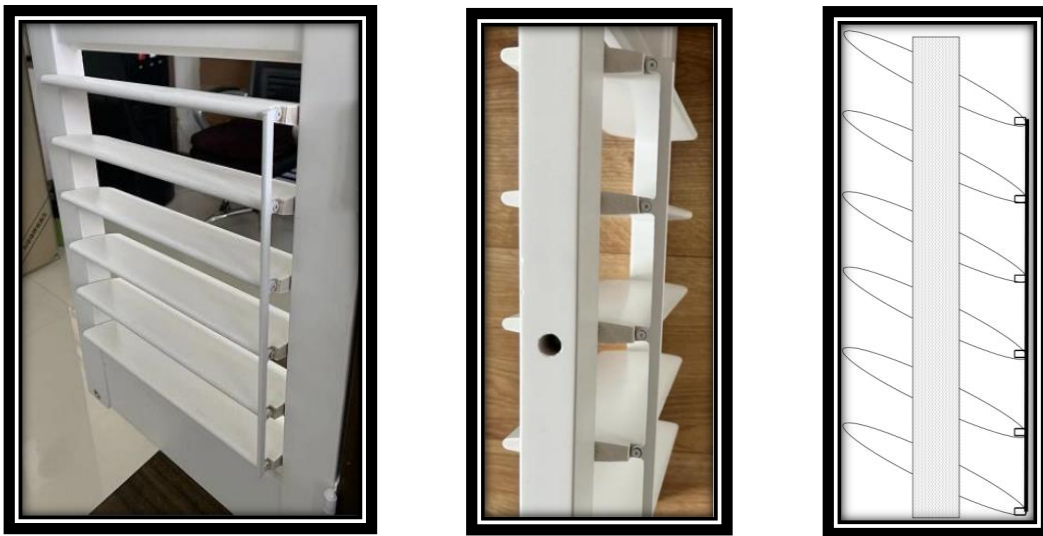

Split Tilt Rods

Each Hidden control is split in the centre after 21 blades for 63mm, 17 blades for 89mm and 15 blades for 114mm. Odd numbers of blades will have 1 blade more on the top Tiltrod. If requested, these splits can be at a specified location if required. Use the drop-down options or specify an approximate height or number of blades for the split position in the **Special Comments** on the order form.

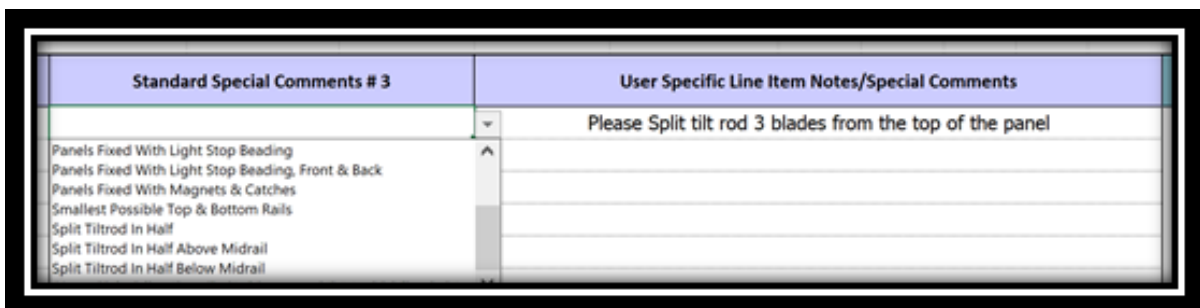

*See Glossary and Reference Charts at the end of this manual for more detailed information

2. Rack & Pinion (Concealed) Tilt Rod

Rack & Pinion Tilt has an internal gear system in which teeth interlock causing the Rack to move relative to the Pinion, connecting the rotational motion of the Louvre blades. This sophisticated tilt system is completely enclosed in the stile. Blades can be tensioned (using tension screws) and changed (with a repair pin) in the usual way. Rack and Pinion attracts a surcharge.

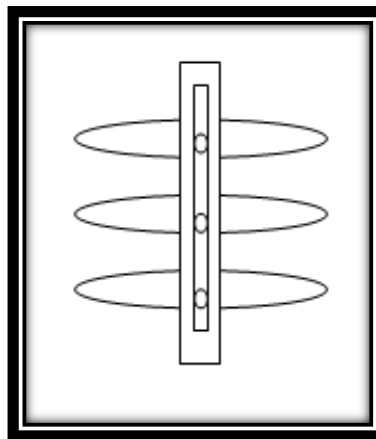

Split Tilt Rods

Each Rack & Pinion control is split in the centre after 16 louvres for 63mm or after 10 louvres for 89mm blades. Odd numbers have 1 blade more on the top tilt. If requested, tiltrods can be split at specified locations. Either use the drop-down options or specify an approximate height or number of blades for the split position in the **Special Comments** on the order form.

3. Centre Tilt Rod

The Centre Tilt Rod is attached with interlocked staples, placed in the centre and front of the panel, with all blades grouped together between the Top & Bottom Rail or Divider Rail. When Bi Folding more than 2 panels, the Centre Tilt Rod is positioned 8mm off centre to allow the panels to fold onto each other without hitting the Tilt Rod.

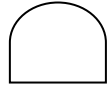

Cross Section of Centre or Offset Tilt Rod

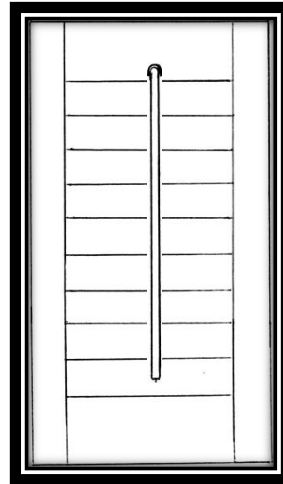

Split Tilt Rods

Each Hidden tilt control is split in the centre after 21 blades for 63mm, 17 blades for 89mm and 15 blades for 114mm. Odd numbers of blades will have 1 blade more on the top Tiltrod. If requested, these splits can be at a specified location if required. Use the drop-down options or specify an approximate height or number of blades for the split position in the **Special Comments** on the order form.

4. Off Set Tiltrod

Is the same system as the Centre Tilt Rod but is placed closer to the hinged side of the Panel. If the panel is fixed, please specify what side the Off-Set Tilt Rod is to be on.

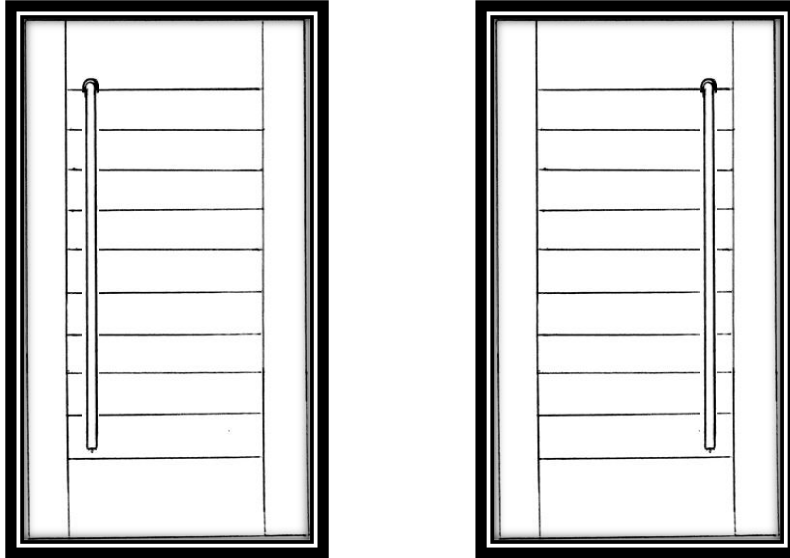

Split Tilt Rods

Each Hidden control is split in the centre after 21 blades for 63mm, 17 blades for 89mm and 15 blades for 114mm. Odd numbers of blades will have 1 blade more on the top Tiltrod. If requested, these splits can be at a specified location if required. Use the drop-down options or specify an approximate height or number of blades for the split position in the **Special Comments** on the order form.

4. Mounting Methods - Summary

4.1 Hinged Panels

Hinged Panels are the best option for most windows and are the most popular mounting method. Most commonly, frames are supplied and non-mortise hinges link the panels to the frame. Hang strips are used with L shaped hinges where no visible frame is preferred. Reveals are rarely straight enough to hinge directly to the side reveals. Pivot Hinges can be used at the top and bottom of panels, with or without Light Stops, when there is no frame required.

4.2 Double Hinged Panels

A Double Hinged Panel is where two panels are hinged together, to fold in a Bi-fold style, without using any tracking. Most commonly, frames are supplied and non-mortise hinges link the panels to the frame and to each other.

4.3 Pivot Hinged Panels

Pivot Hinges can be used at the top and bottom of Panels when there is no frame required. Pivot Hinges are available in White and Stainless Steel only.

4.4 Fixed Panels

We offer three Fixed mounting options, to fix panels in position so that the blades can open and close but the panels are held in place without hinges. Some panels can be removed, others are permanently fixed.

4.5 Bifold Panels

Bi Fold Panels are an ideal option for room dividers and covering a sliding door, giving the ability to fold the panels away leaving a full view of the outside world.

4.6 Sliding Panels

Sliding Panels can be used in a number of situations, but they are commonly used over sliding doors.

4.7 Photo Gallery of Mounting Methods

Hinged Panels



*See Glossary and Reference Charts at the end of this manual for more detailed information

Double Hinged Panels



*See Glossary and Reference Charts at the end of this manual for more detailed information

Fixed Removable Panels



*See Glossary and Reference Charts at the end of this manual for more detailed information

Bi Fold Panels



*See Glossary and Reference Charts at the end of this manual for more detailed information

Sliding Panels



*See Glossary and Reference Charts at the end of this manual for more detailed information

5. Hinged Panels

Please refer to the [Shutter Range & Mounting Methods Reference Charts](#) for Hinged Panels minimum and maximum dimensions.

5.1 Layout Codes for Hinged Panels

When configuring the “Layout Code” for Hinged Panels, the letters below apply:

- ‘L’ - Left Hand Side Hinge
- ‘R’ - Right Hand Side Hinge
- ‘T’ - T Post (for hinging panels off)
- ‘D’ - D Mould
- ‘B’ - Bay Post (135° post used for Bay windows)
- ‘C’ - Corner Post (90° post used for Corner Windows)

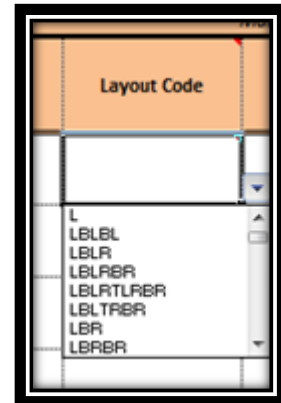

NOTE: When ordering, the Panel Quantity **must match** the Layout Code.

One Panel



Two Panels



Three Panels

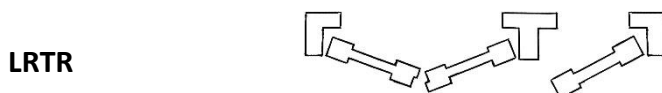
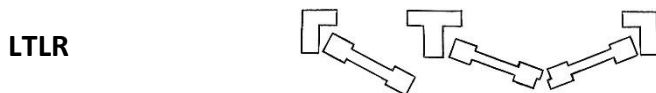

*See Glossary and Reference Charts at the end of this manual for more detailed information

LTLTL

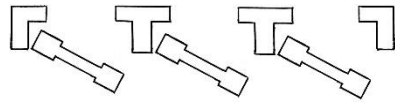

RTRTR

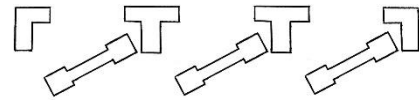

Four Panels

LRTLRL

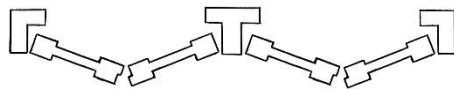

LTLRTR

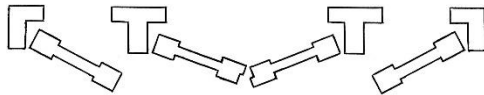

RTLRTL

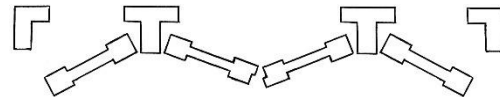

Five Panels

LTLRRTL

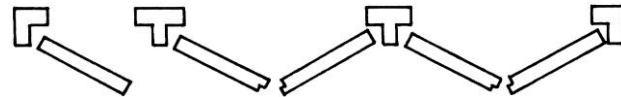

Six Panels

LRTLRLTL

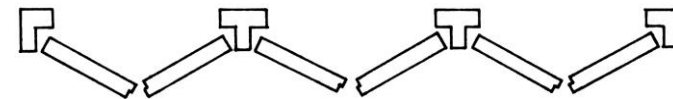

Other configurations can be used depending on:

- The number of panels required and
- The function for each opening.

Note: In some cases, magnets can also be used to mount some or all panels, to the frame instead of hinges. This method is called Fixed with Magnets*

*See Glossary and Reference Charts at the end of this manual for more detailed information

5.2 Framing for Hinged Panels

Inside Fit Framing Options

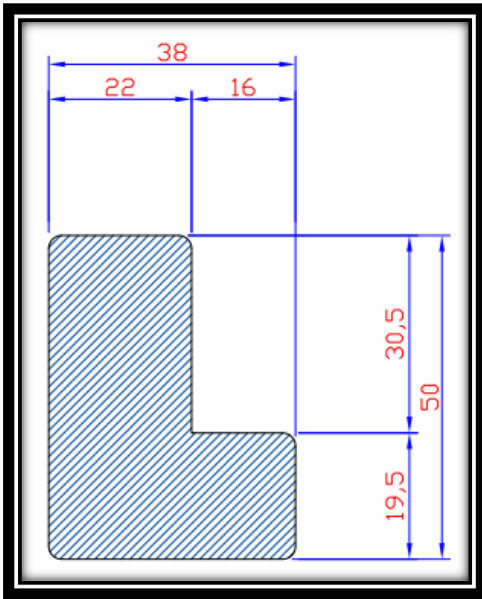

Small L Frame Flat

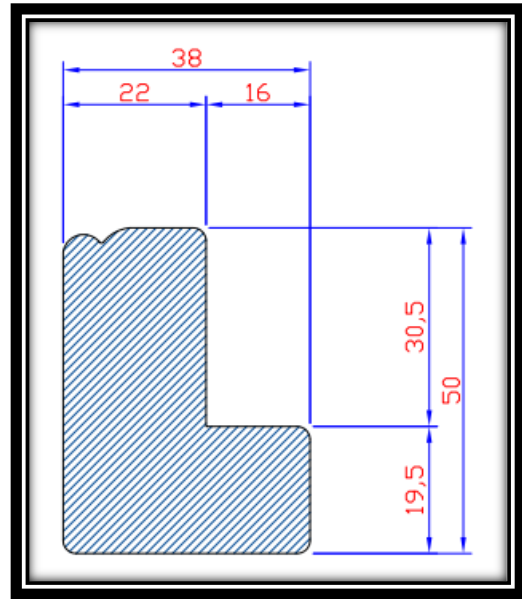

Small L Frame (Beaded Option)

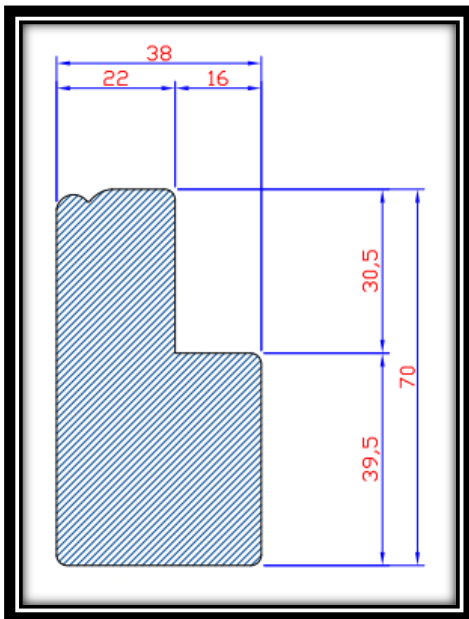

Medium/Large L Frame (Beaded Option)

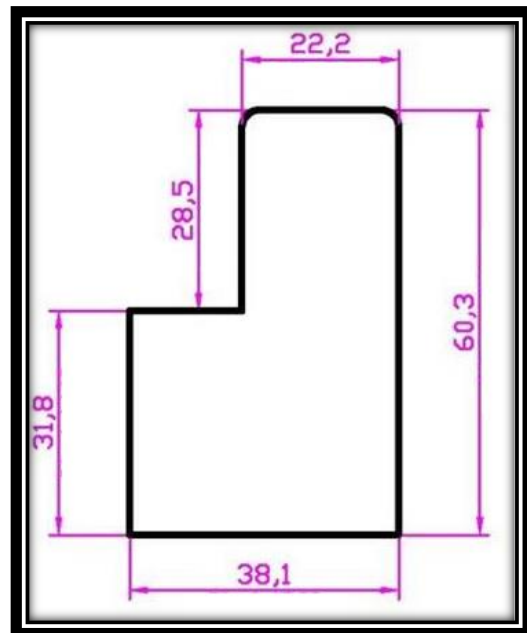

Medium L Frame Flat

*Not available in the Laminated Coatings

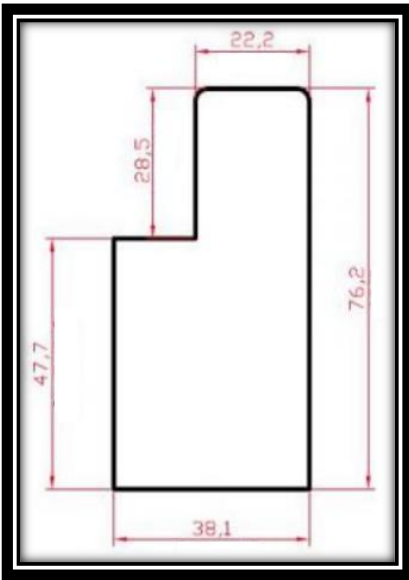

Large L Frame Flat

*Not available in the Laminated Coatings

L Frame is screwed, nailed or glued to the sides and top and bottom of the reveal. It is important to pack out any framework to ensure it is square, with any gaps being filled with matching No More Gaps or a similar filler. If the Beaded L Frames are required, please ensure correct option is selected in Frame Type. See example below;

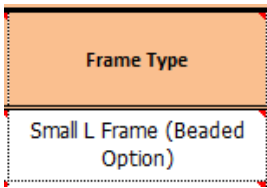

L Frame Inside Mount (Top View)

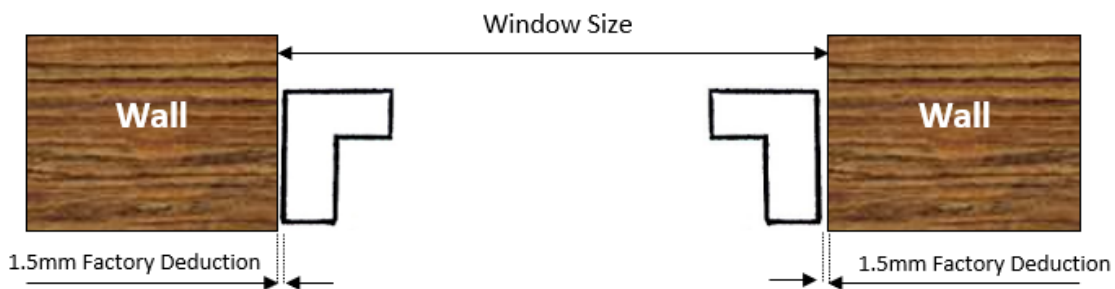

L Frame Inside Mount (Side View)

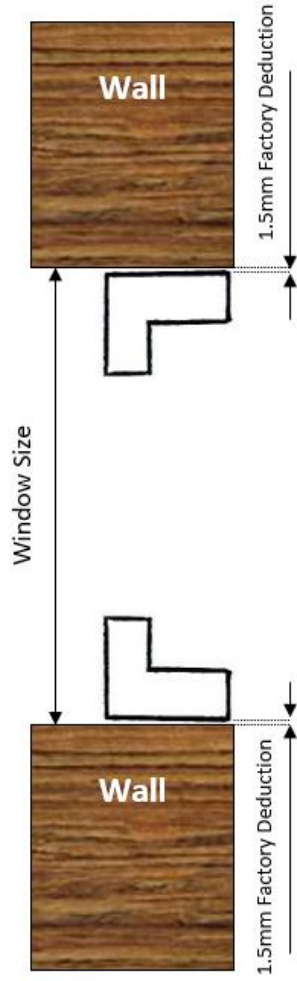

*See Glossary and Reference Charts at the end of this manual for more detailed information

L Frame Inside Mount (Top View)

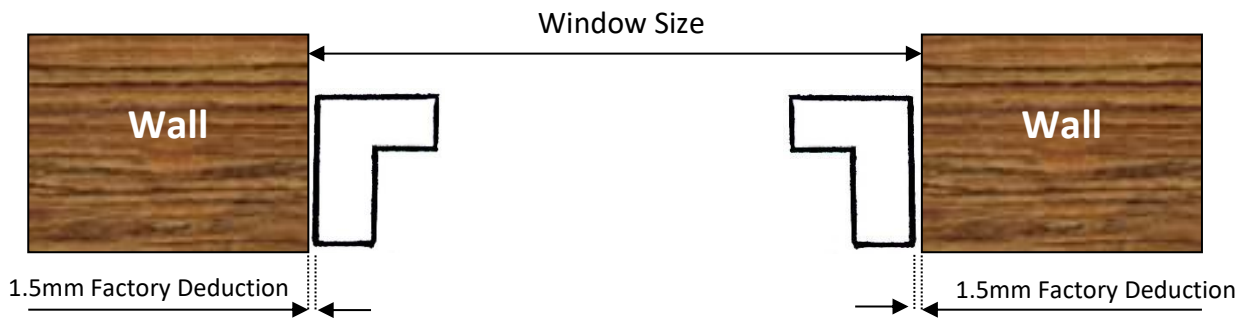

L Frame Inside Mount (Side View)

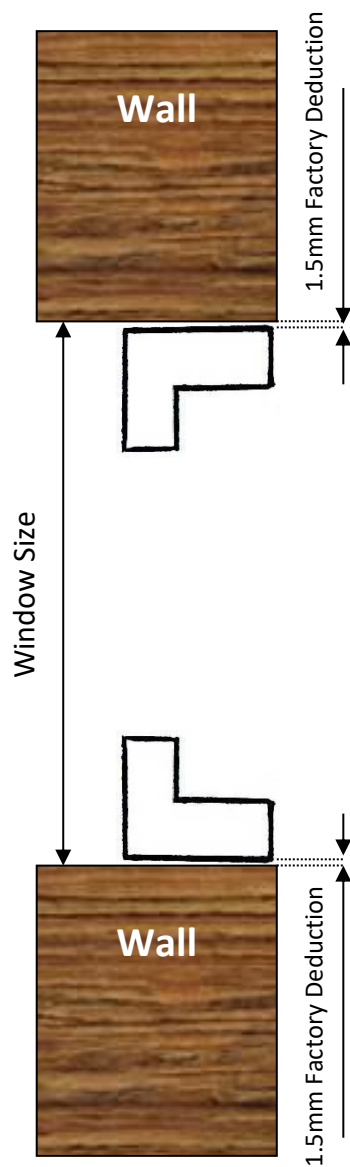

*See Glossary and Reference Charts at the end of this manual for more detailed information

Outside Mount

Frames are required for most outside fit applications; they give the ability to hang the shutter panel square in the frame, clear of any protrusions that may prevent the blades from rotating. Called Face Fit* L Frame, the Cover Strip neatly hides mounting holes and screw heads used to secure the frame.

- Face Fit L Frames are supplied with Pre-Drilled holes as standard. Please specify 'no holes' if you do not want these.

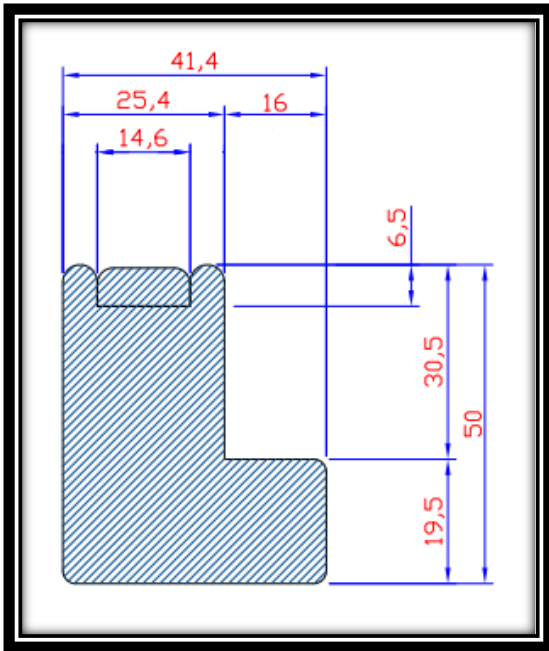

Small Face Fit L Frame

*Not available in the Laminated Coatings

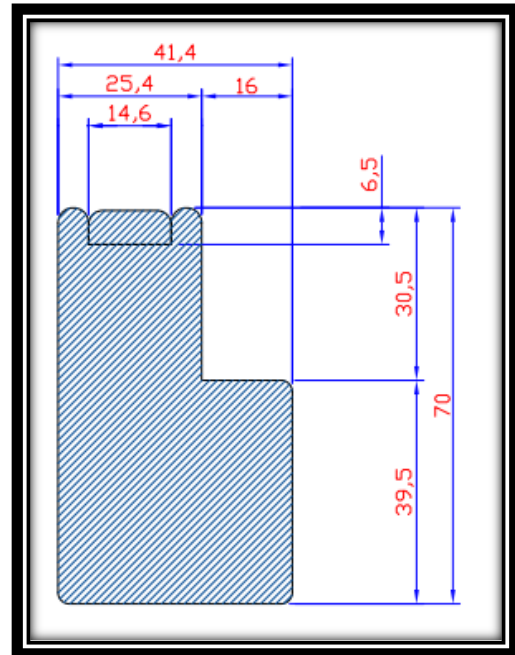

Medium / Large Face Fit L Frame

*Not available in the Laminated Coatings

L Frame Outside Mount (top view)

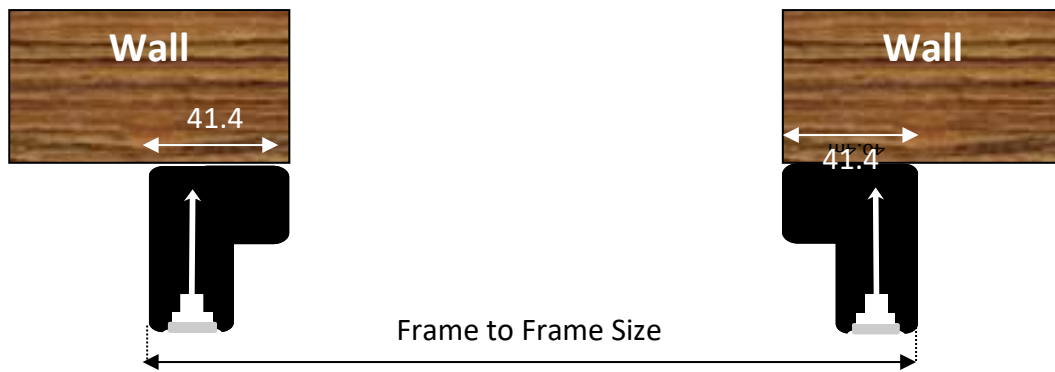

NOTE: No deductions to frame size are made for Face Fit applications.

L Frame Outside Mount (side view)

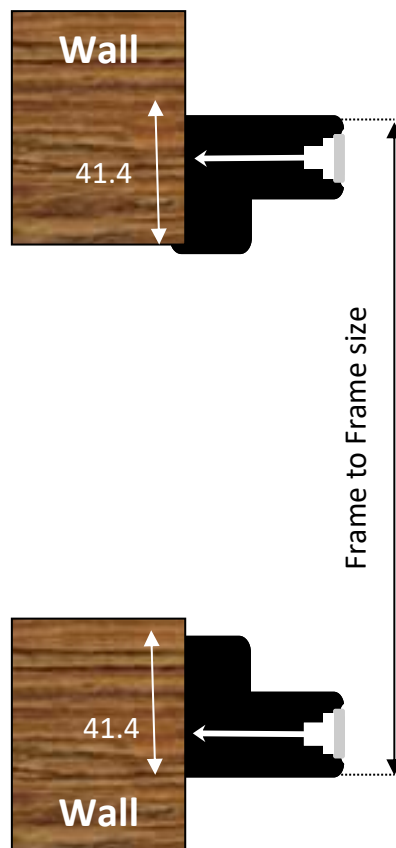

Z Frames (Reveal Fit)

Z Frames are commonly used with and without an architrave in the opening. This frame will wrap around the reveal edge, making it ideal for covering non-square windows. Z Sill Frame can be used along with Z Frames where it's unable to wrap around the opening. For example: the bottom sits on a kitchen bench, the top goes to a bulkhead ceiling, or the side is adjacent to a perpendicular wall.

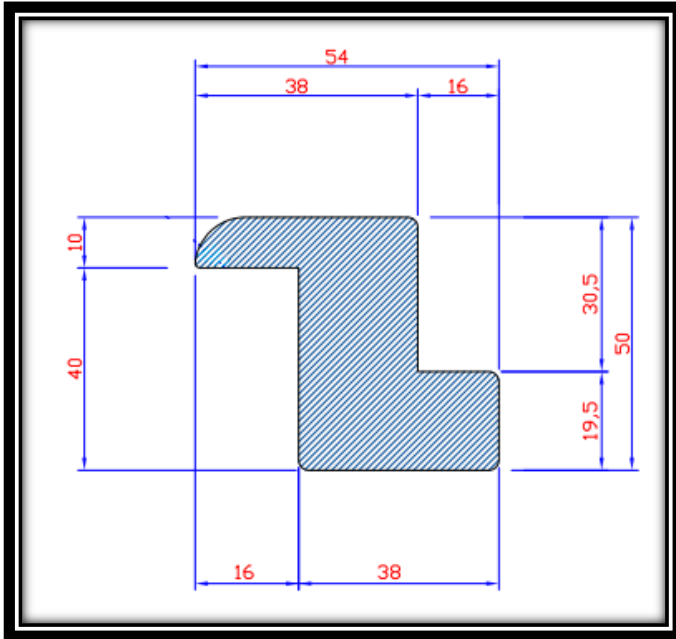

Bullnose Z Frame

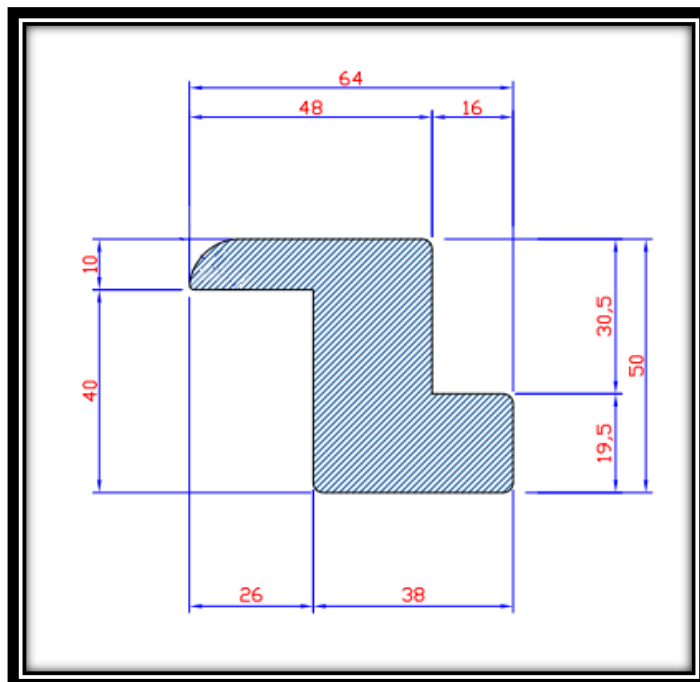

Large Bullnose Z Frame

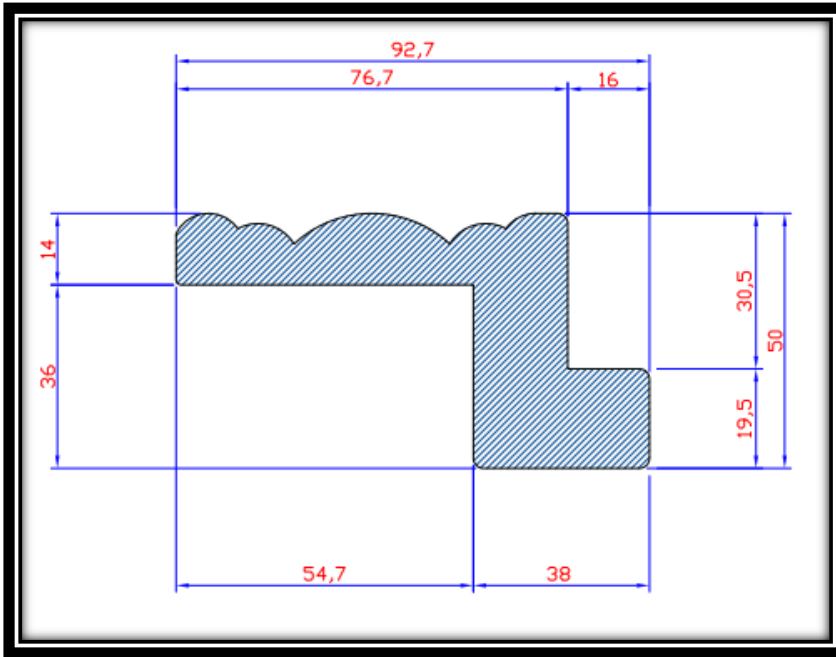

Large Z Frame

*Not available in the Laminated Coatings

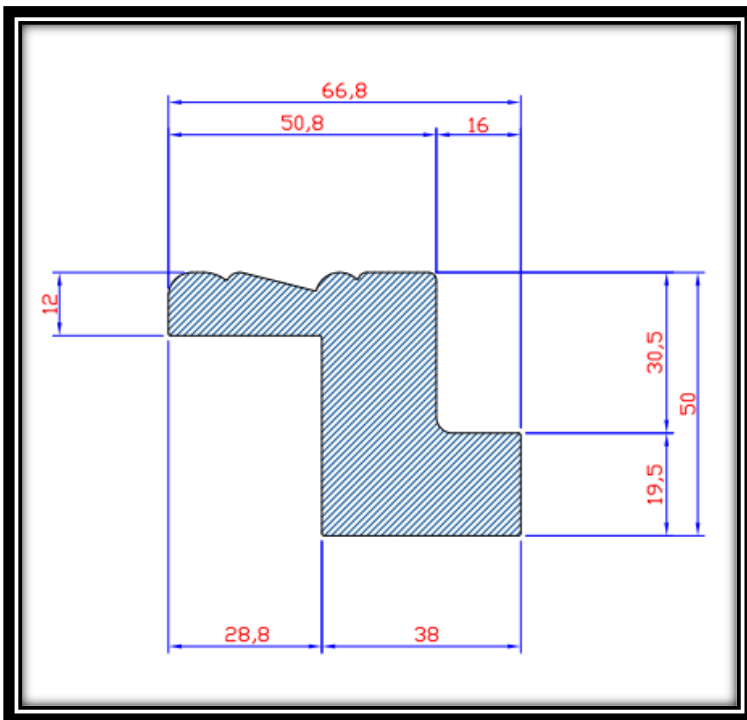

Standard Z Frame

*Not available in the Laminated Coatings

Frame (top view)

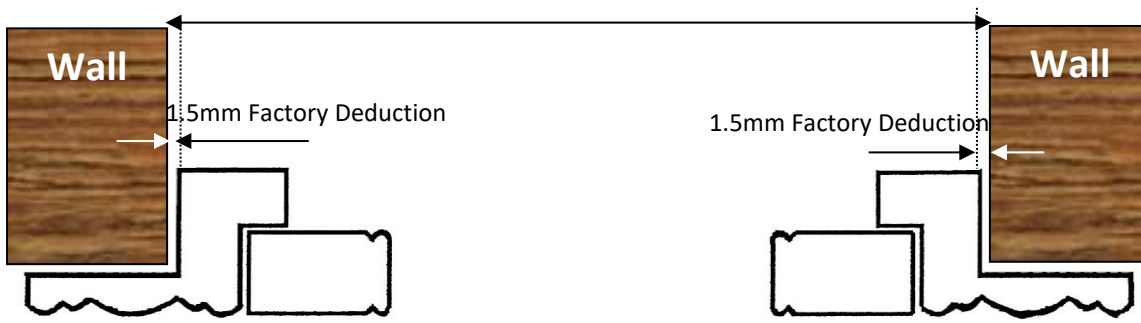

Z-Frame (side view)

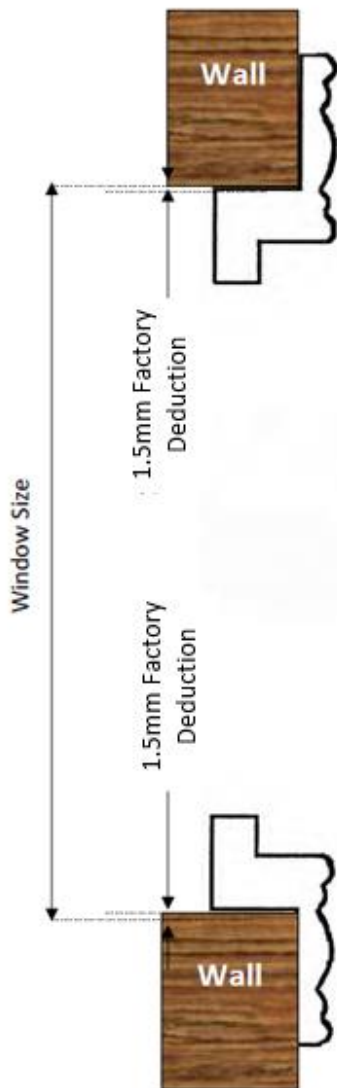

*See Glossary and Reference Charts at the end of this manual for more detailed information

5.3 Hanging Strip with Light Stop

Hanging Strip* is an excellent option for Inside Mount situations if the desired aesthetic is to have no visible frames. This method is quick, easy and allows adjustment in a non-square opening.

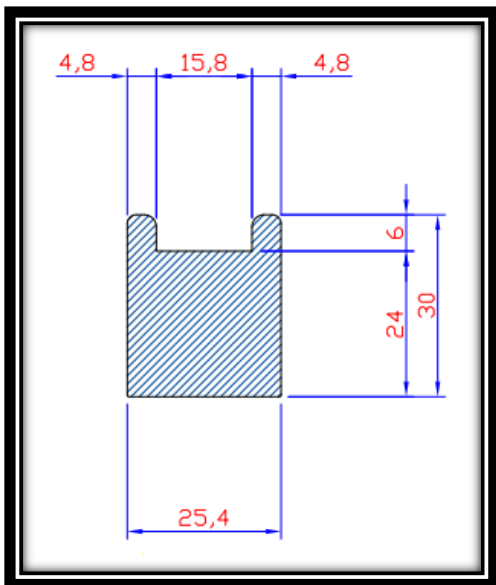

Hanging Strip

*Not available in the Laminated Coatings

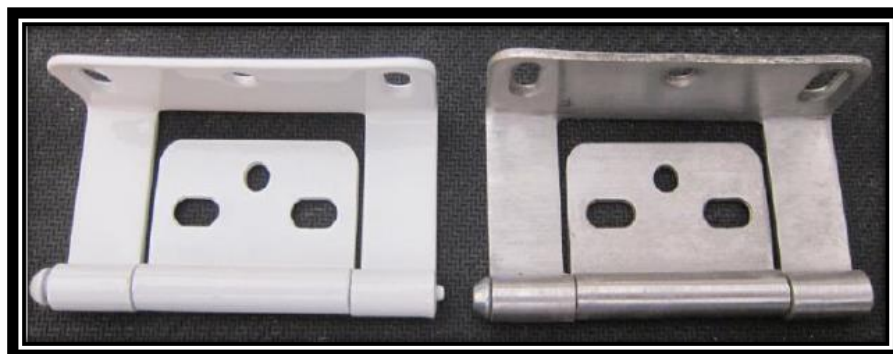
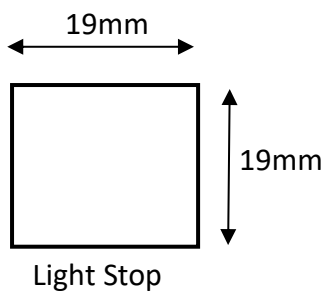

*See Glossary and Reference Charts at the end of this manual for more detailed information

Hanging Strip Inside Mount (top view)

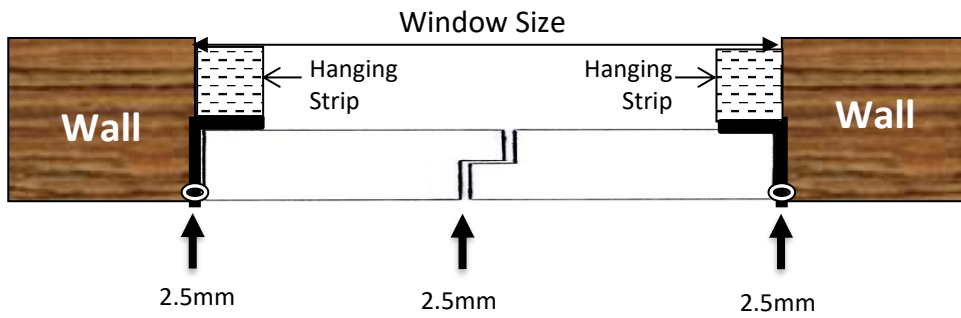

Hanging Strip Inside Mount (side view)

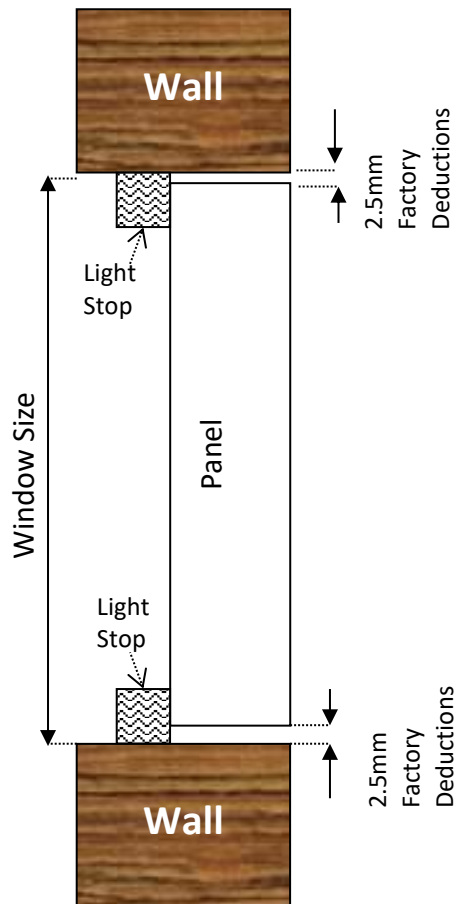

- If Light Stop is ordered it will be supplied cut to size with magnet catches attached.

5.4 Double Hinged Panels

Double Hinged Panels enable up to 4 panels to be installed without T Posts.

Layout Codes for Double Hinged Panels

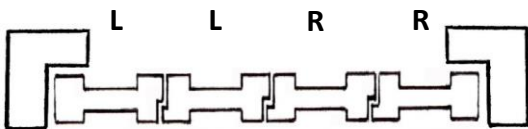
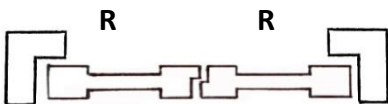
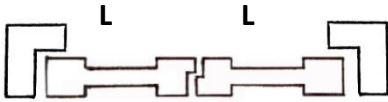

5.5 T Posts

T posts are used when more than two panels are required in an opening. Use a “T” in the layout code to show the configuration. For example, LRTL is four panels, a left and right hinged pair of panels, either side of a single T Post.

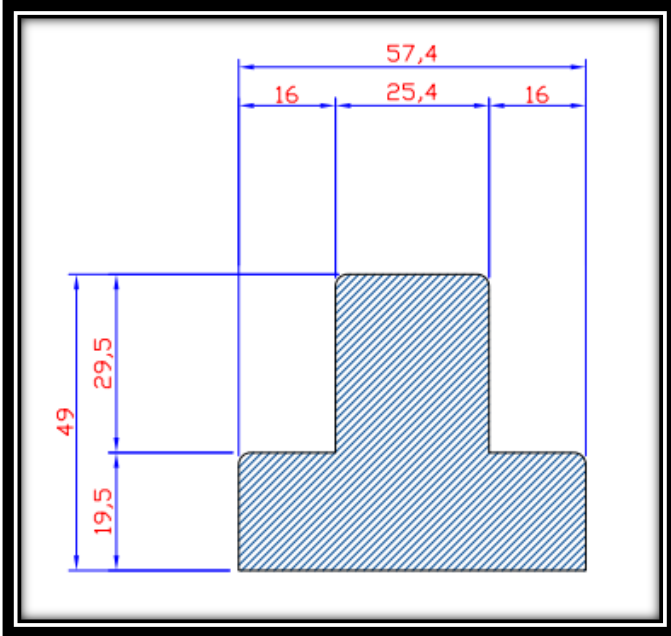

T Post

Example:



	Quantity	1 st T-Post (mm)	2 nd T-Post (mm)
T Posts	2	600	1800

*See Glossary and Reference Charts at the end of this manual for more detailed information

5.6 Pivot Hinged Panels

Pivot Hinges can be used at the top & bottom of panels when no frame is required. Pivot Hinges are available in white powder-coated and stainless-steel option, for both Reveal Fit and Face Fit applications (surcharges apply).



Reveal Fit Hinge



Face Fit Hinge



Magnetic Catch

Layout Codes for Pivot Hinged Panels

When configuring the "Layout Code" for Pivot Hinged Panels, the letters below apply:

- 'L' - Left Hand Side Hinge
- 'R' - Right Hand Side Hinge
- 'D' - D Mould

NOTE: When ordering, the Panel Quantity **must match** the Layout Code.

Events Alert		Mandatory Fields	
Window Type	Mounting Method	Layout Code	Frame Type
Standard	Pivot Hinged	<div style="border: 1px solid black; padding: 2px;"> L LD-R L-DR LR R </div>	

*See Glossary and Reference Charts at the end of this manual for more detailed information

6. Fixed Panels

There are three options for Fixed Panels:

6.1 Fixed Removable Panels Using U Channels

Using a deep U Channel at the top and a shallow U Channel at the bottom, panels are lifted up into the top U channel and placed onto the bottom U Channel. They are easy to remove by simply lifting the panel up and out of the bottom U Channel.

Please refer to the [Shutter Range & Mounting Methods Reference Charts](#) for Fixed Removable Panels minimum and maximum dimensions.

Any additional extras required **must** be noted in the **Extra's Section** of the Order Form. Please see example below;

Item #	Quantity	Length	Material & Product	Extra's	Colour
1	2	1200	Timber Eco	Light Stop 31.8mm x 9.5mm	Pure White (W190)
2					
3					

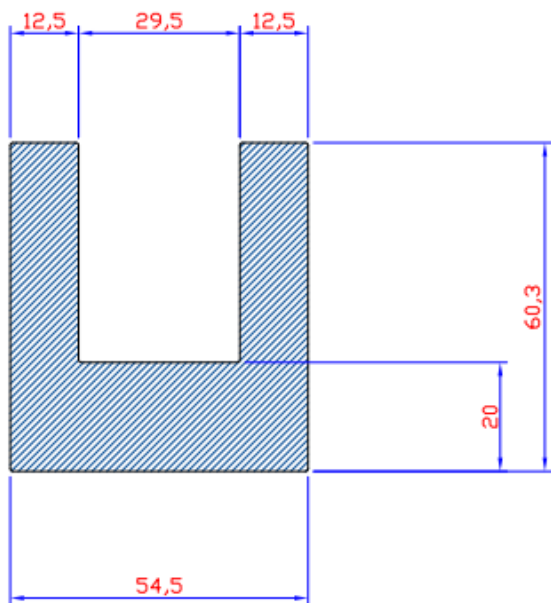

Large U Channel (For Top)

*See Glossary and Reference Charts at the end of this manual for more detailed information

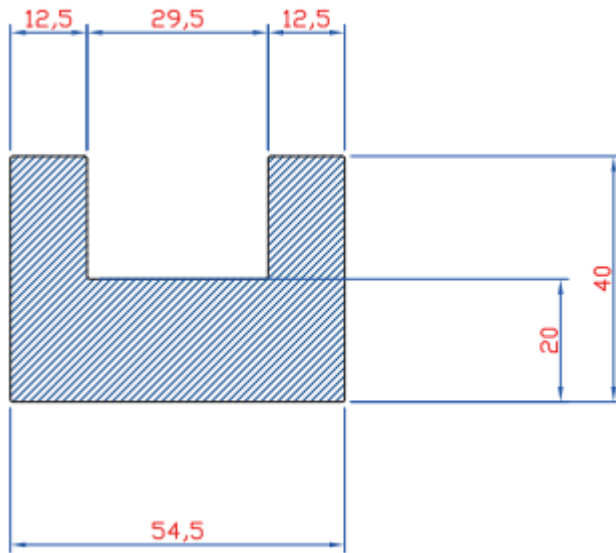

Small U Channel (For Bottom)

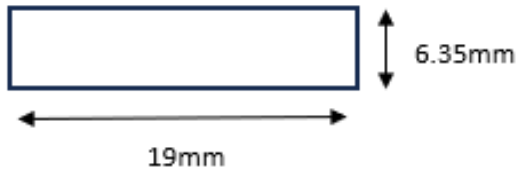

Light Stop (For Sides)

Fixed/Removable Panel (side view)

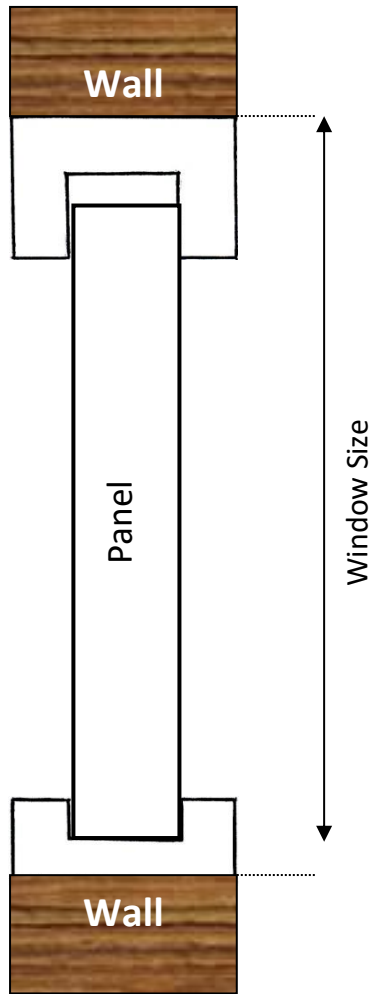

Fixed/Removable Panel (top view)

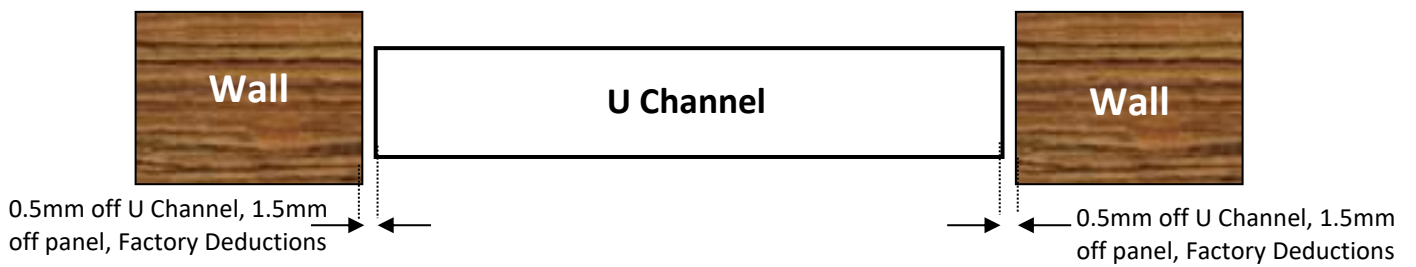

*See Glossary and Reference Charts at the end of this manual for more detailed information

6.2 Fixed Removable Panels Using Magnets

Panels Fixed with Magnets are fit into frames identical to hinged panels, except instead of hinges, an extra set of magnets and catches are fitted. This option can be used in instances where a tap, piece of furniture or other impediment prevents hinged panels from pivoting.

6.3 Fixed with Light stop Beading on Front & Back

Panels Fixed with Light stop are suitable for reveal fit only. Each item is supplied with 4 lengths of 19mm x 19mm Light stop. Additional Light stop for back of panels needs to be ordered in Extra's on Order Form. Lengths of Light stop are fixed to the top, bottom and either side of the opening; then the panel(s) are placed against this Light stop and another row of Light stop is fixed on the opposite face, holding the panels permanently in position. These panels are not removeable, therefore are a safe option between rooms.



7. Bi Fold Panels

Please refer to the [Shutter Range & Mounting Methods Reference Charts](#) for Bi Fold Panels* minimum and maximum dimensions.

7.1 Layout Codes for Bi Fold Panels

The layout codes for Bi Fold Shutters are “L” for Left and “R” for Right, to convey the specified stacking direction of the panels:

Below are some examples of Bi Fold configurations.

LL

Two panels stacking Left

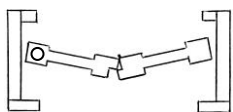

RR

Two panels stacking Right

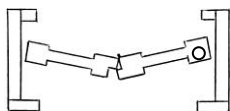

LLRR

Four panels centre opening

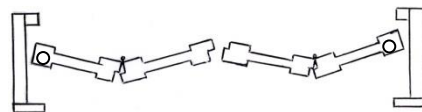

LLLL

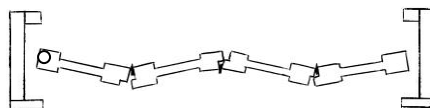

LLRRRR

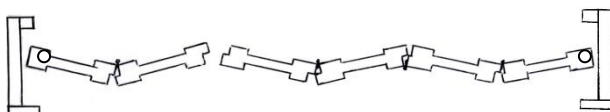

RRRR

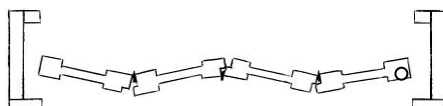

*See Glossary and Reference Charts at the end of this manual for more detailed information

LLLRRR

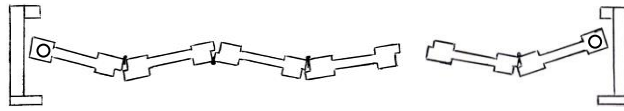

LLLLL

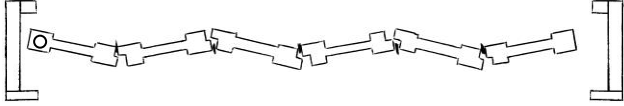

RRRRR

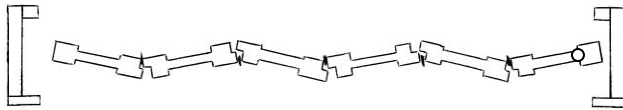

LLLRRRR

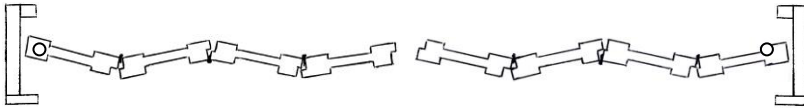

LLLLLLL

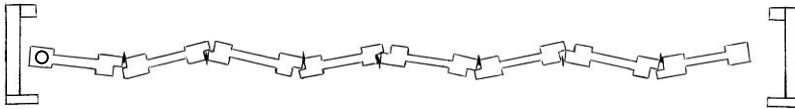

RRRRRRR

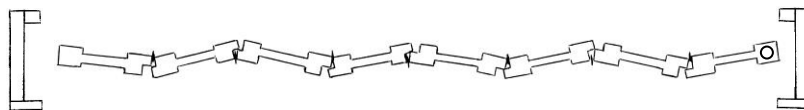

7.2 Frames for Bi Fold Panels

For Face Fit Bi Fold shutters, frames are required and will be supplied as per your order. For Reveal Fit, frames are the default; they are recommended, but not always required*.

Headboard and Side Frames

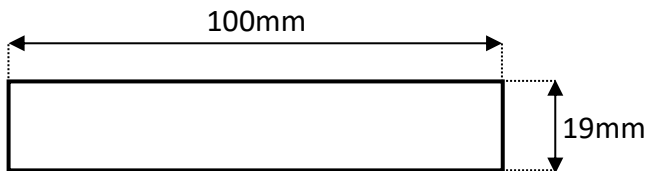

Mounting Block (for Headboard)

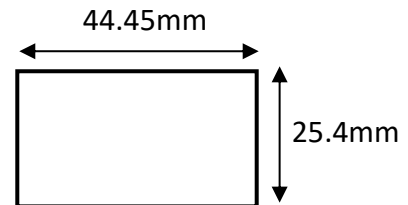

Fascia

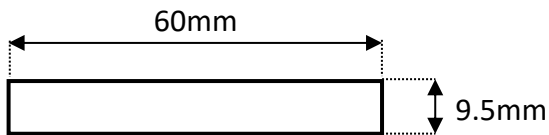

For Reveal Fit

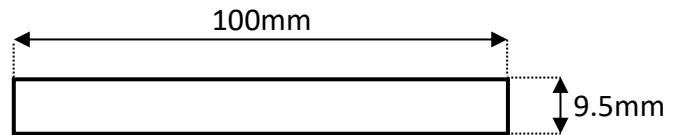

For Face Fit

Light Block (for front edge of Side Board)

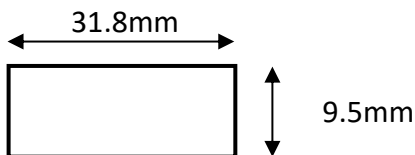

Mounting Block (for Sideboard)

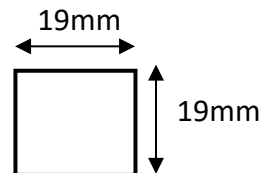

*See Glossary and Reference Charts at the end of this manual for more detailed information

7.3 Bi Fold Hardware

Bi Fold Hardware

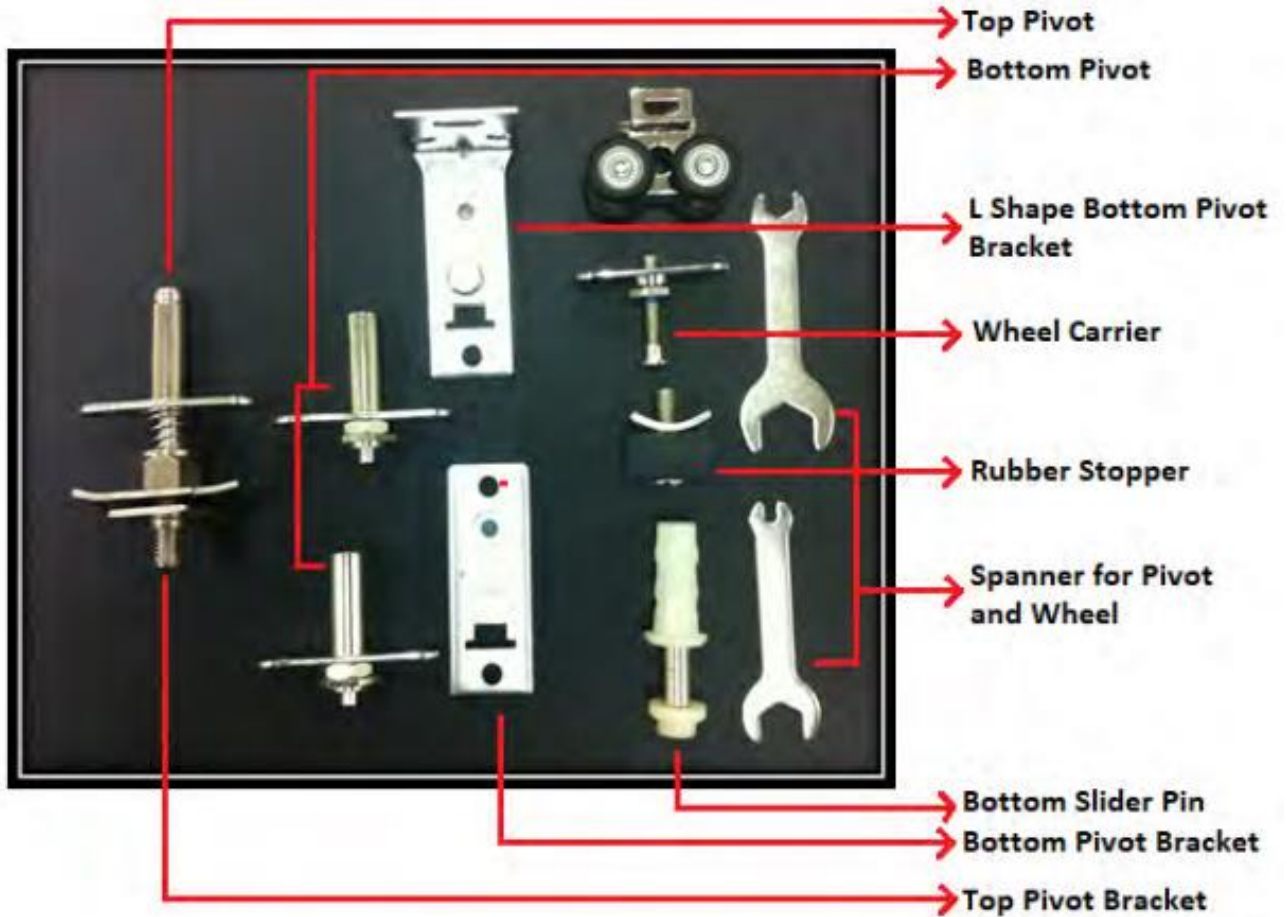

7.4 Tracking for Bi Fold Panels

Top Track



W24mm x H21mm

Bottom Track

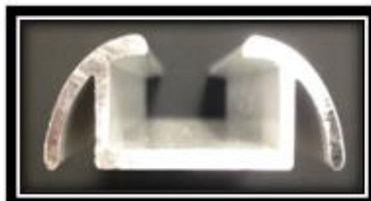

W32mm x H8 mm

Bottom Track In Board)



W23mm x H13mm

*See Glossary and Reference Charts at the end of this manual for more detailed information

7.5 Bi Fold Inside Reveal Mount

Please ensure there are no handles, mullions or winders that will interfere with the operation of the pivoting panel and the open blades.

Bi Fold Inside Mount with no sideboard (top view)

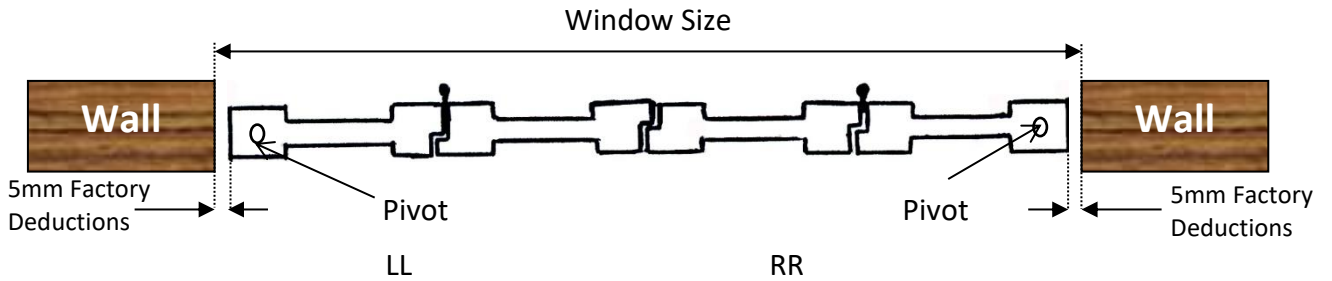

Bi Fold Inside Mount with no sideboard (side view)

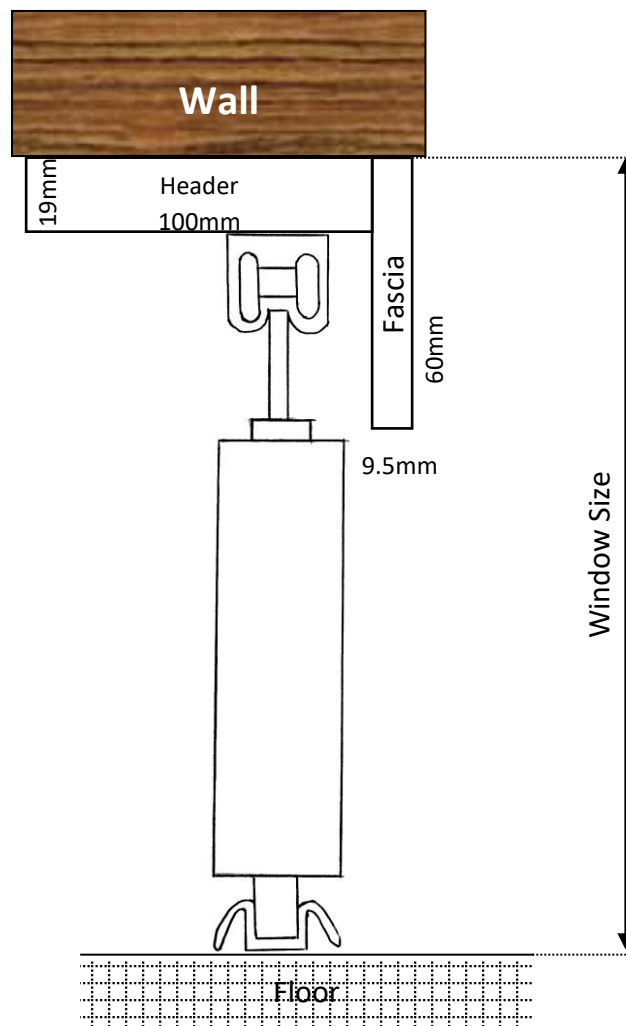

*See Glossary and Reference Charts at the end of this manual for more detailed information

7.6 Bi Fold Face Fit Mount

When ordering Face Fit Mount for Bi Fold shutters, side frames to match can be supplied. Select YES in the Left and Right Frame sections.

Bi Fold Outside Mount with top and side frames (Top view)

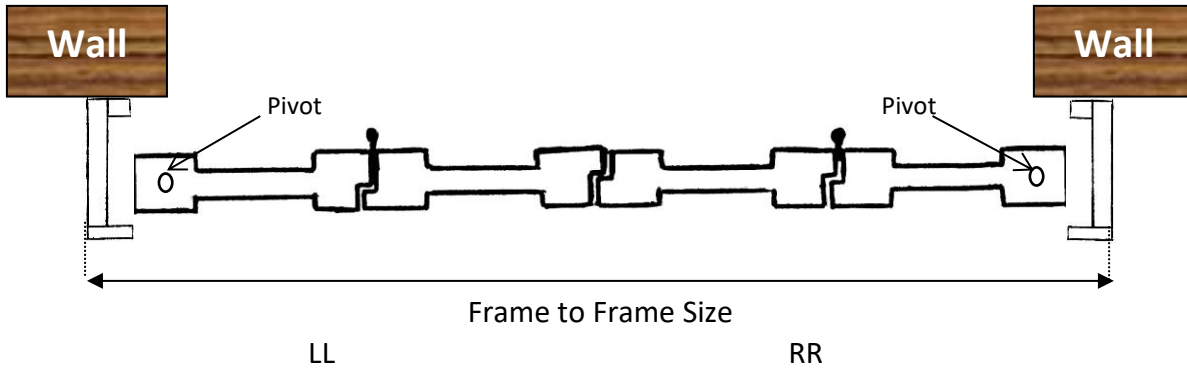

Bi Fold Outside Mount with no sideboard (side view)

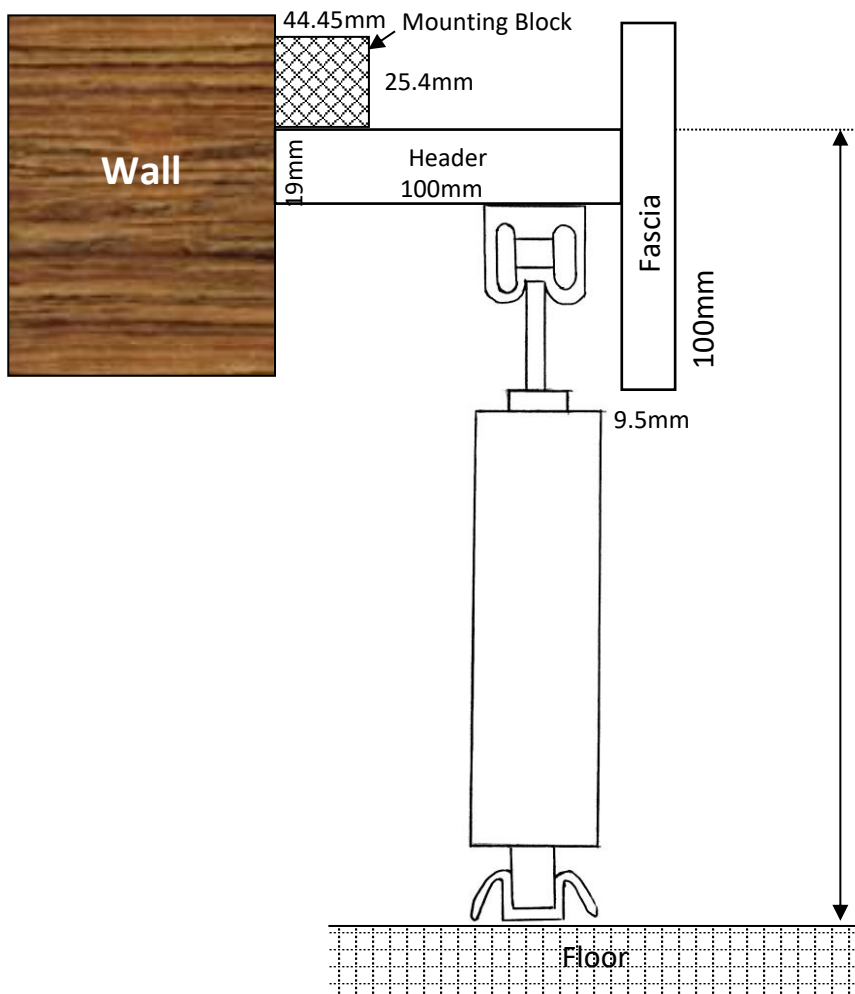

NOTE: Top of headboard to the floor or bottom of the opening **MUST** be supplied for Outside Fit.

E.g. If mounting above existing architrave please add 19mm to the architrave to floor measurement to allow for the headboard.

7.7 Bottom Track Options for Bi Fold Panels

Option A – Track Only

Track mounted to the floor.

Track Height is 8mm.

Recommended option for hard, flat level surfaces.

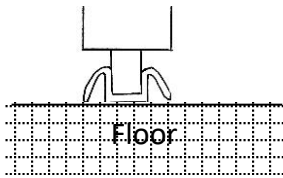

Option B – Track On Board

Track mounted to Frame Board. Track Height is 8mm plus the Board Height of 19mm.

If mounting headboard and sideboards to the wall, outside an architrave, please consider that the Frame may need to be cut back by the thickness of the architrave in order to line up the floor track with the top track and for the front edge of the Frame to be flush with the front edge of the sideboards.

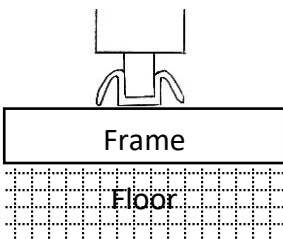

Option C – Track In Board

Track mounted inside the Board.

Board Height of 19mm.

Recommended option for soft non- level surfaces e.g. plush carpets etc. Board is supplied the same depth as the Headboard and Sideboard. If mounting HB and SB to the wall, outside an architrave, please consider that the Board may need to be cut back by the thickness of the architrave in order to line up the floor track with the top track and for the front edge of the Board to be flush with the front edge of the sideboards.

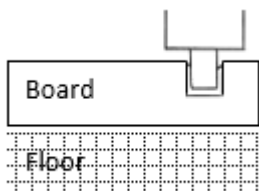

7.8 Bifold Extras

Flush Bolt

*Surcharge Applies



Ring Pull

*Surcharge Applies



8. Sliding Panels

Please refer to the [Shutter Range & Mounting Methods Reference Charts](#) for Sliding Panels minimum and maximum dimensions.

8.1 Layout Codes for Sliding Panels

Below are some examples of Sliding configurations.

'B' Back – the panel is placed on the back track.

'M' Middle – the panel is placed on the middle track (only when 3 tracks are required).
These Panels these will ONLY slide in the **CLOSED** position.

'F' Front – the panel is placed on the front track

Two Panels

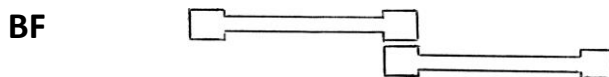

Three Panels

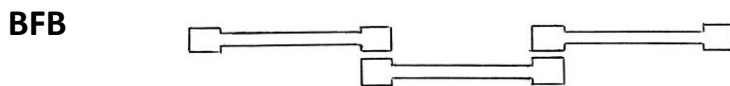

Four Panels

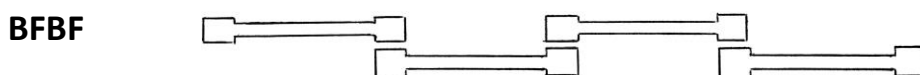
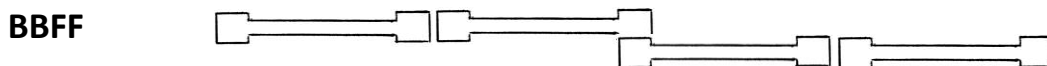
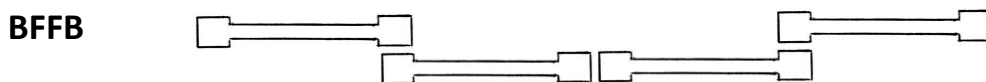

Six Panels

(Sliding Closed only)

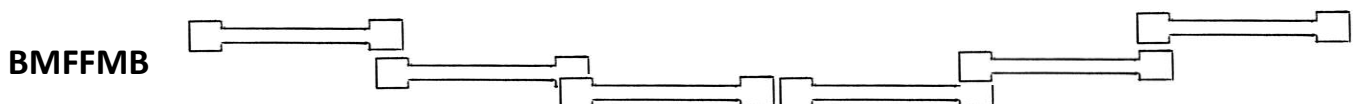

*See Glossary and Reference Charts at the end of this manual for more detailed information

8.2 Sliding Panel Frames

Headboard and Side Frames

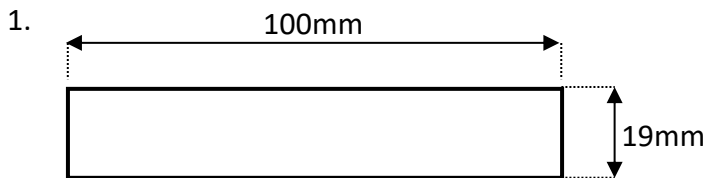

100mm Headboard – 2 Tracks of panels with 63mm, 89mm or 114mm blades will pass with the blades **closed** (only).

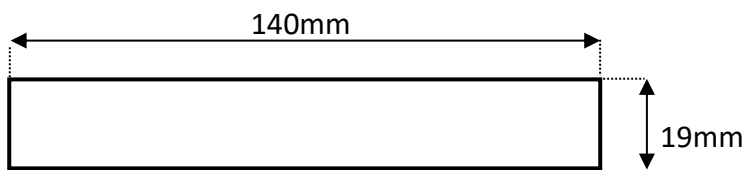

140mm Headboard – 2 Tracks of panels with 63mm blades will pass with the blades open*;
2 Tracks of panels with 89mm or 114mm blades will pass with the blades closed (only).
3 Tracks of panels will pass blades closed (only)

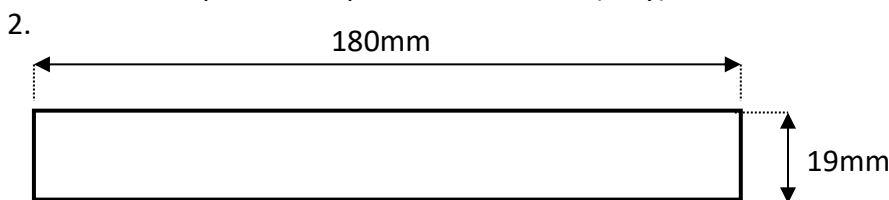

180mm Headboard – 2 Tracks of panels with 89mm blades will pass with blades open* if fitted to the wall without architrave; with an architrave that is less than 50mm wide and no more than 12mm deep; or directly onto an existing architrave.

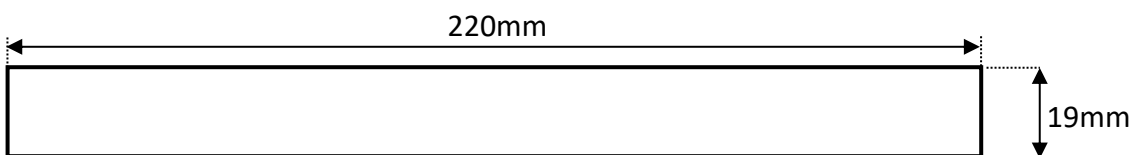

220mm Headboard – 2 Tracks of panels with 89mm blades will pass with blades open

Mounting Blocks

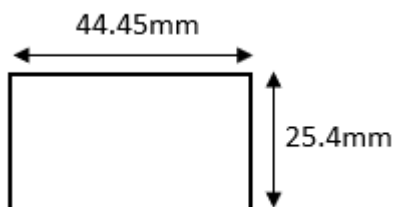

Used to mount Headboard

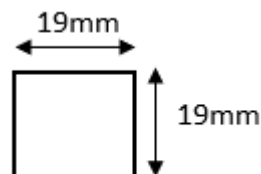

Used to mount Sideboard

*See Glossary and Reference Charts at the end of this manual for more detailed information

Fascia

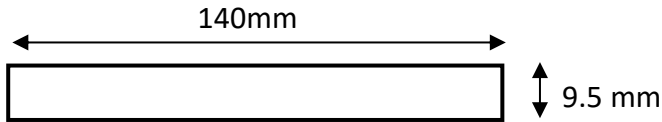

Guidelines for Sliding Panels and Related Headboard Size Options

		Headboard Sizes (2 Tracks Only)			
		100mm	140mm	180mm	220mm
Blade Size					
63mm		Closed	Open or Closed	Open or Closed	Open or Closed
89mm		Closed	Closed	Open or Closed	Open or Closed
114mm		Closed	Closed	Closed	Closed

Maximum number of available tracks is 3, these will ONLY Slide in the CLOSED position

Light Blocks

Large Light Block – Used on front edge of Sideboards

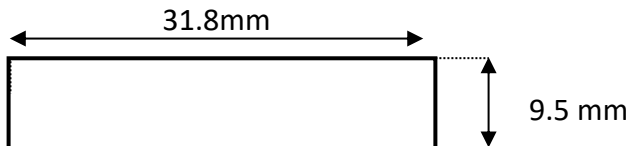

Light Blocks – Used between panels when ordered as sliding “Open”

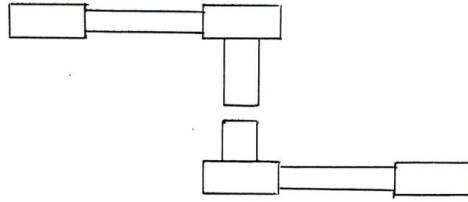

For 63mm Blades - 2 x 25mm x 19mm Light Blocks are supplied

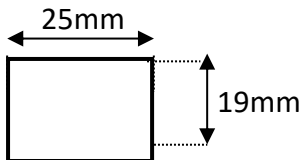

For 89mm Blades - 2 x 25mm x 30mm Light Blocks are supplied

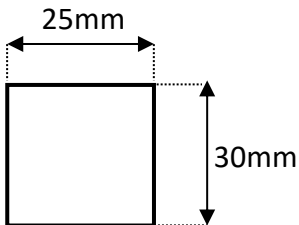

For 114mm Blades - 2 x 44.45mm x 25.4mm Light Blocks are supplied

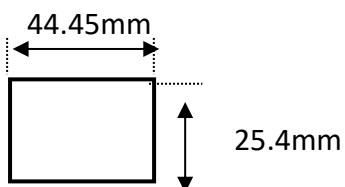

Default Overlap

The default overlap allowance, between panels on the front and back tracks, for both sliding open and closed, is Approx 40mm

Sliding L Bracket

We recommend the use of the L-Bracket for all headboards to provide structural support at installation (this assists the mounting block).

L-Brackets are automatically supplied with our Sliding & Bi-Fold Shutters.

There are 3 different L-Bracket sizes (95mm, 135mm & 175mm) The bracket size supplied is dependent on the headboard size that is ordered.

1 x bracket is supplied per 500mm in width

Headboard Size	Default Bracket Size
100mm	95mm
140mm	135mm
180mm	175mm
220mm	175mm

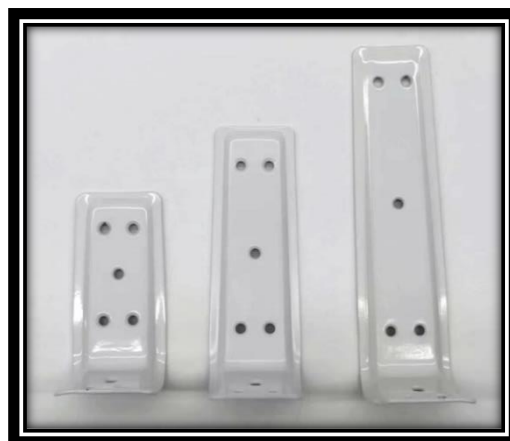
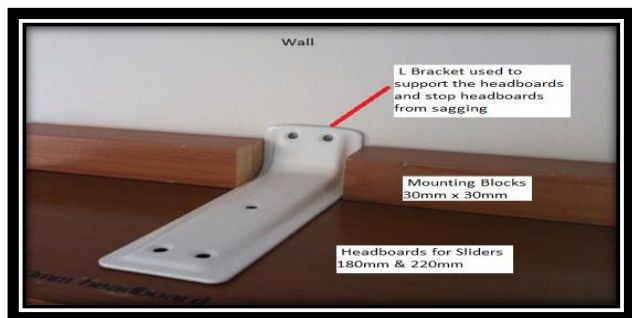

8.3 Top Hung Sliding System

The Top Hung Sliding System is our original Sliding System where the panels are hung from the top track, with the bottom of the panel running along the bottom track with a bottom slider pin for guidance.

Tracking and Other Hardware

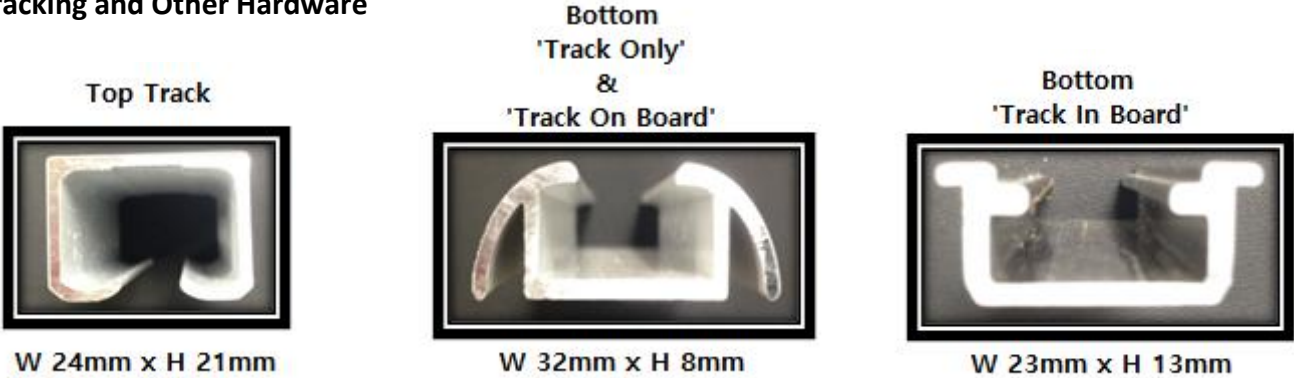

Other Hardware



Floor Guide



Flush Bolt
**Surcharge Applies*

*See Glossary and Reference Charts at the end of this manual for more detailed information

8.4 Inside Mount with Sideboard

(Top View)

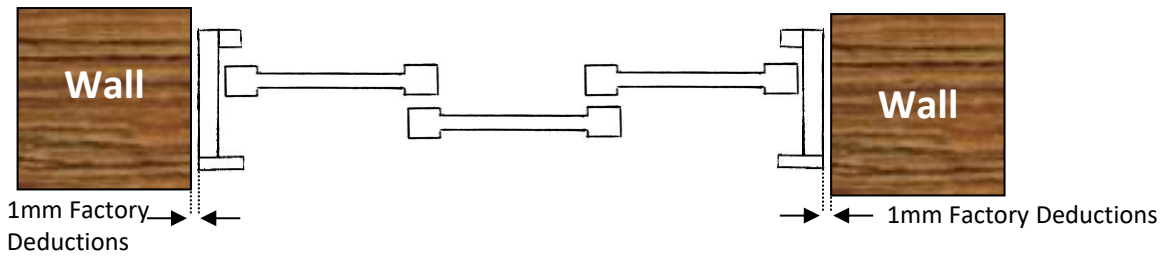

Inside Mount (side view)

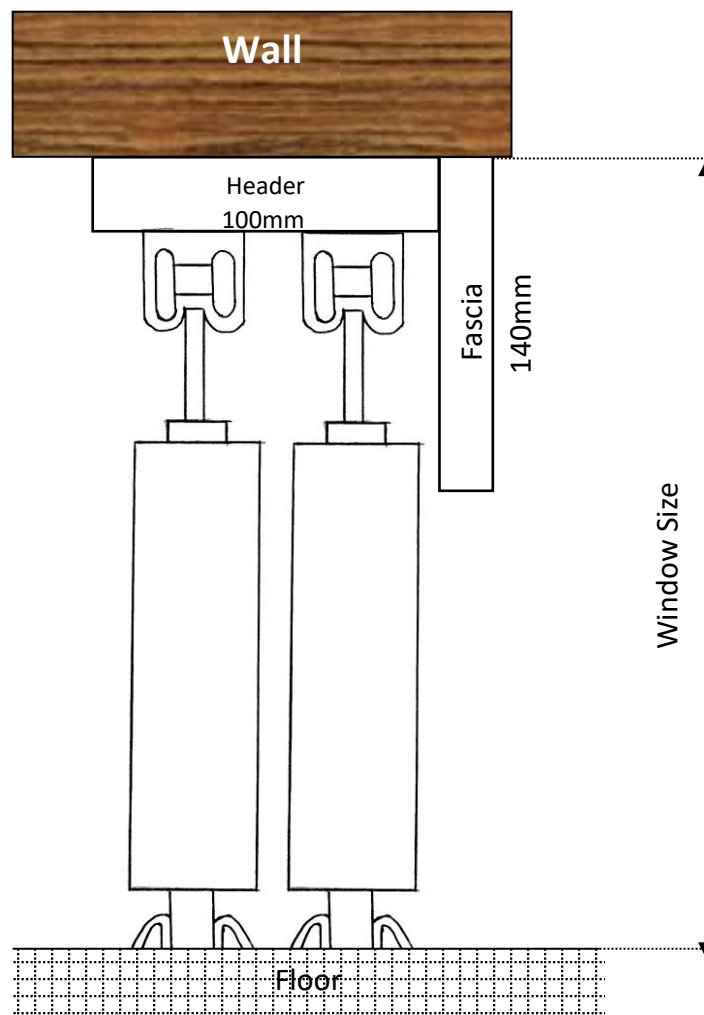

Please ensure there is sufficient depth in the reveal to mount IN if this option is chosen. (Please refer to the Guidelines for Sliding Panels and Related Headboard Size Options chart above).

8.5 Face Fit Mount with Sideboards

(Top View)

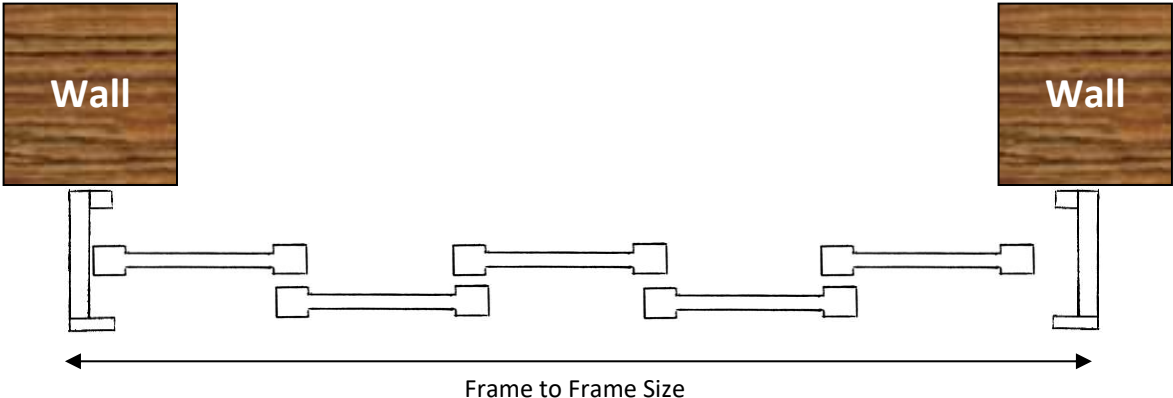

Outside of Frame measurement **MUST** be supplied for Outside Fit. The Gross Opening Width needs to include the 20mm Sideboards on both the left and righthand sides of the opening. The Gross Opening Height needs to include the 20mm Headboard depth. In other words, the measurements given should be outside of sideboards to outside of sideboard and top of Headboard to the floor.

Face Fit Mount (side view)

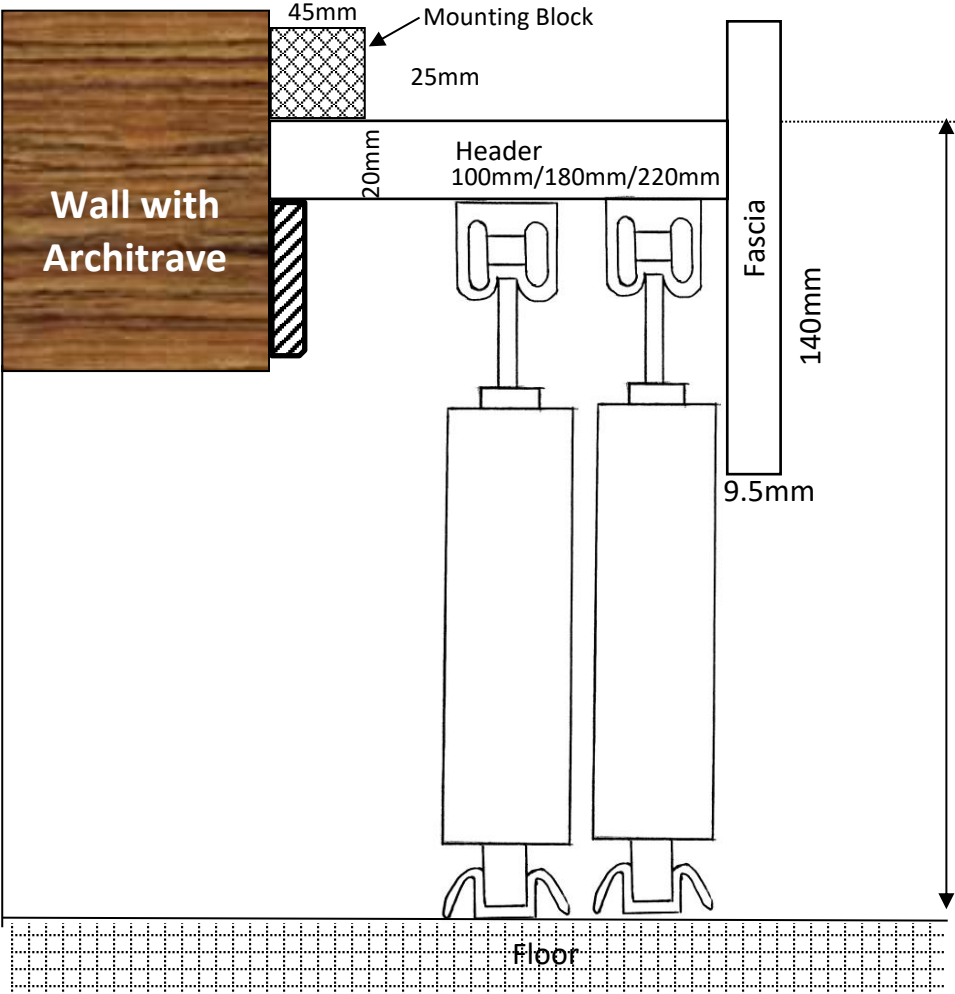

NOTE: Top of headboard to the floor or bottom of the opening **MUST** be supplied for Outside Fit.

E.g.: If mounting above existing architrave please add 20mm to the architrave to floor measurement to allow for the headboard.

*See Glossary and Reference Charts at the end of this manual for more detailed information

8.6 Default Fascia Position

For INSIDE Mount, the top of the fascia is flush with the top surface of the headboard. For FACE FIT (OUTSIDE mount) the top of the fascia will sit 37 mm above the top surface of the headboard.

8.7 Default Track Positions

Tracks are fitted to headboards (and bottom boards) by the factory depending on if ordered sliding open, or closed and the blade size ordered, following these specifications:

1. Distance between the front track and the back of the fascia is approx 10mm (back of fascia to centre of the front track is approx 22mm)
2. Distance between the tracks for sliding closed is approx 10mm (centre of track to centre of track is approx 34mm)
3. Distance between tracks for 63mm blades, sliding open is approx 49mm (centre of track to centre of track is approx 73mm)
4. Distance between tracks for 89mm blades, sliding open is approx 74mm (centre of track to centre of track is approx 98mm)
5. Distance from the back track to the back of the headboard is dependant on the headboard width ordered. Clearance required for:
 - a. 63mm blades with a hidden control is approx 31mm (approx 43mm from the centre of the back track)
 - b. 89mm blades with a hidden control is approx 43mm (approx 55mm from the centre of the back track)

8.8 Bottom Track Options for Top Hung Sliding Panels

Option A – Track Only

Track mounted to the floor.

Track Height is 8mm.

Recommended option for hard, flat level surfaces.

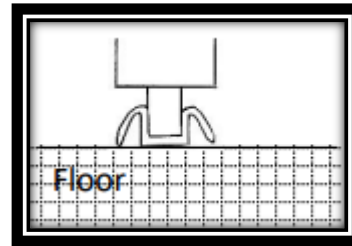

Option B – Track On Board

Track mounted to Frame Board.

Track Height is 8 mm plus the Board Height of 19mm.

Recommended option for Soft non- level surfaces e.g. plush carpets etc.

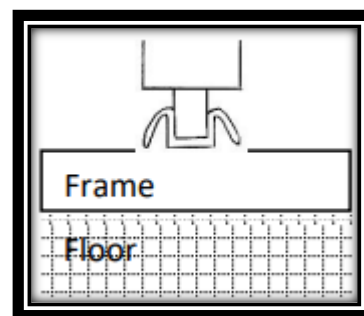

Option C – Track In Board

Track mounted inside the Board.

Board Height of 19mm.

Recommended option for soft non- level surfaces e.g. plush carpets etc.

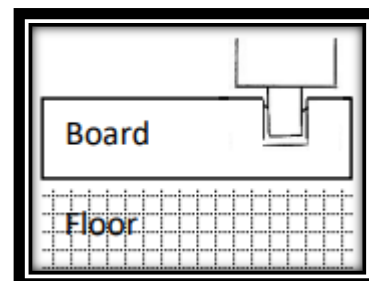

Option D – Floor Guide

No bottom track is used, this Floor Guide is fitted where the panels overlap.



8.9 Sliding Panels – Bottom Wheel Sliding System

The Bottom Wheel Sliding System is our newest shutter addition, allowing for better weight distribution. The bottom-mounted wheels support the weight of the shutter and allow for easy and smooth sliding across the bottom track with the top of the panel running along a top U-Channel for guidance.

When promoting bottom wheel sliding shutters, you can emphasize the following **Selling Features**:

- Smooth Operation – the bottom wheel ensures effortless and smooth sliding, minimising the effort needed for opening and closing
- Better Weight distribution
- Low Maintenance - The bottom wheel design typically requires less maintenance compared to other systems, with fewer parts exposed to wear and tear
- Aesthetic Appeal – Provides a modern and sleek look that complements any interior
- Quiet Operation – The bottom wheel system generally results in quieter operation compared to other sliding systems





Bottom Track In Board

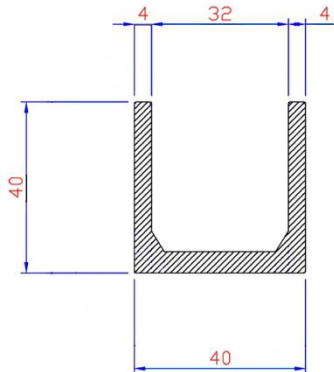
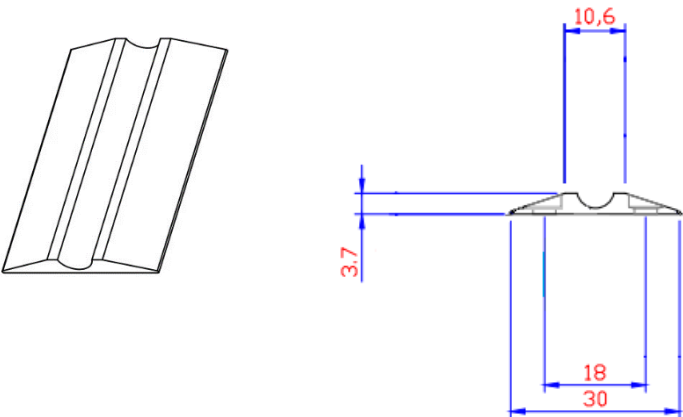
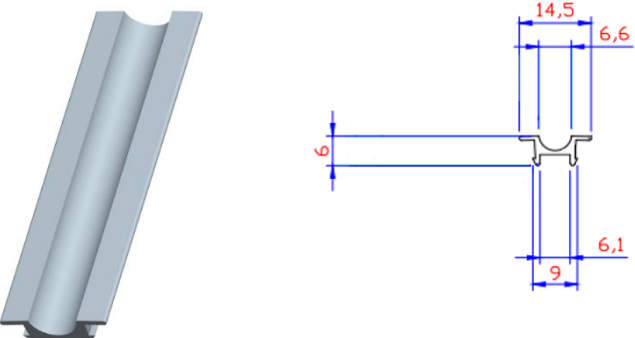

Back of panels – Bottom wheels

8.10 Tracking and hardware for Sliding Panels – Bottom Wheel Sliding System

<p>Top U Channel</p>	
<p>Bottom Track (Track Only)</p>	
<p>Bottom Track (Track In Board)</p>	
<p>Bottom Wheel - adjustable</p>	

*See Glossary and Reference Charts at the end of this manual for more detailed information

8.11 Sliding Panels into a Corner with Mitred Headboards

Sliding panels can be used in a corner doorway situation with mitred Headboards and Fascia's to eliminate a Butt and Thru scenario. This presents itself with a far neater aesthetic appeal.

Please Note:

1. The below drawing should be sent to support the standard order form. Email shutterorders@pacificwholesale.com.au
2. The drawing MUST include the measurements and also specify whether the measurements provided are Front or Back of Headboard measurements.

Sliding Panels into a corner with Mitred Headboards

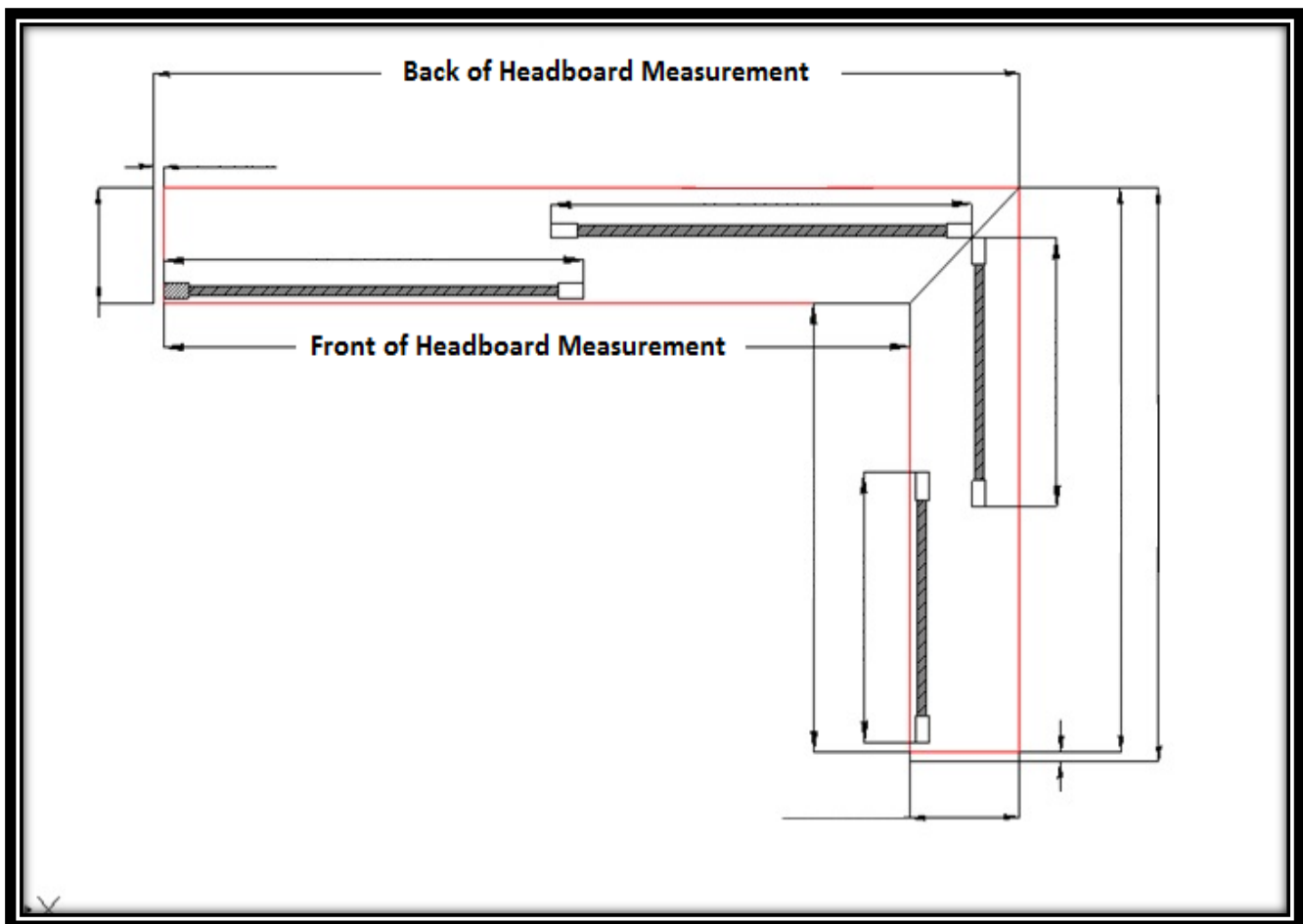

8.12 Combo (Co Joined) Panels for Sliding Panels



Combo Panels (above) 2 Panels = Layout Code BBFF

Sliding Combo Panels* (Co-Joined) are hinged together with a stepped hinge and Rabbet Stiles in the centre to reduce any light gaps. Due to the high risk of transport damage, we do not offer single panels with a centre stile.

When ordering Combo Panels “**Combo Panels**” must be selected in the standard **Special Comments** section of the order form, and the Layout code is double the panel quantity as a Combo Panel is considered as 1 single panel e.g.

2 panels = BB FF

4 Panels = BB FF FF BB

Standard Special Comments # 1
Combo Panels

Top View of a Combo Joined Panel

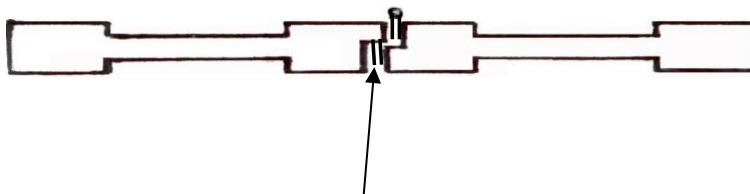

Hinged together and ordered as one panel

*See Glossary and Reference Charts at the end of this manual for more detailed information

9. Special Requirement Windows & Options

There are a large variety of options that can be supplied for windows with special requirements. Some of these include: Bay Windows, Corner Windows, Box Windows, Shapes and Door cut outs. All special requirement windows attract a surcharge. Every requirement is different due to the product type and the application. This section will help to outline the details and special requirements needed to manufacture these types of shutters.

9.1 Bay Windows

Shutters with Bay Posts are arguably the best window treatment for Bay Windows. They look great, fit neatly, accommodating 135° opening angles effectively without gaps or overlaps. Ordering this option requires supplying a **Bay Window Diagram** (Diagram template supplied) to support the standard order form.

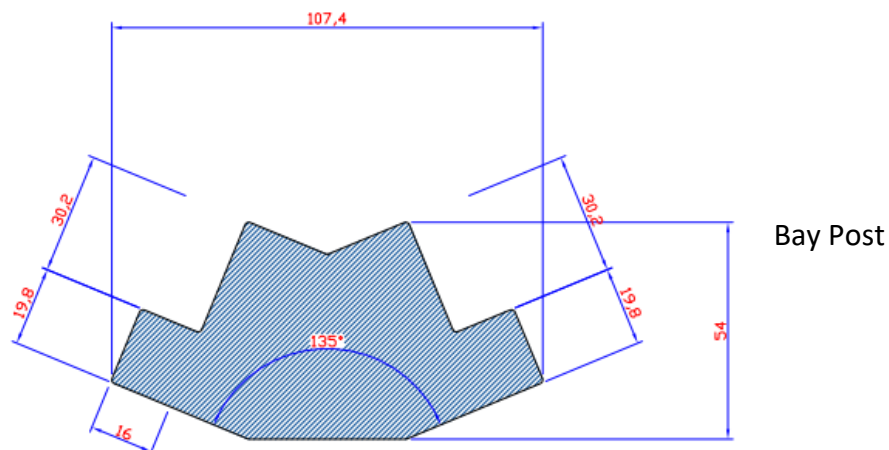

*See Glossary and Reference Charts at the end of this manual for more detailed information

9.2 Corner and Box Windows

Like Bay Windows, Shutters with Corner Posts are considered to be the best window treatment for Corner and Box Windows. They look great, fit neatly, accommodating one, or two **90°** opening angles effectively without gaps or overlaps. Ordering this option requires supplying a **Corner or Box Window Drawing** (diagram template supplied) to support the standard order form.

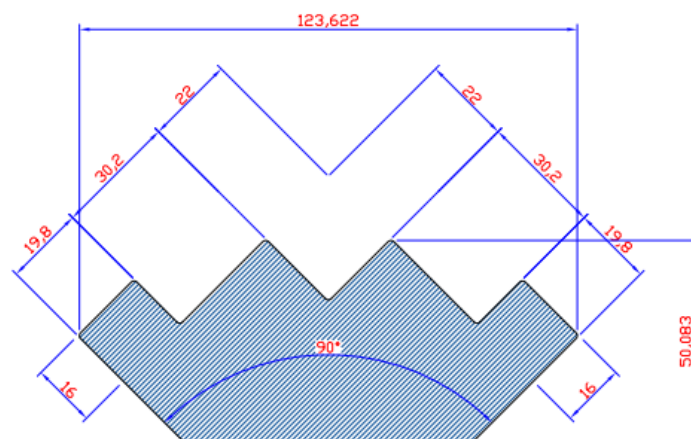
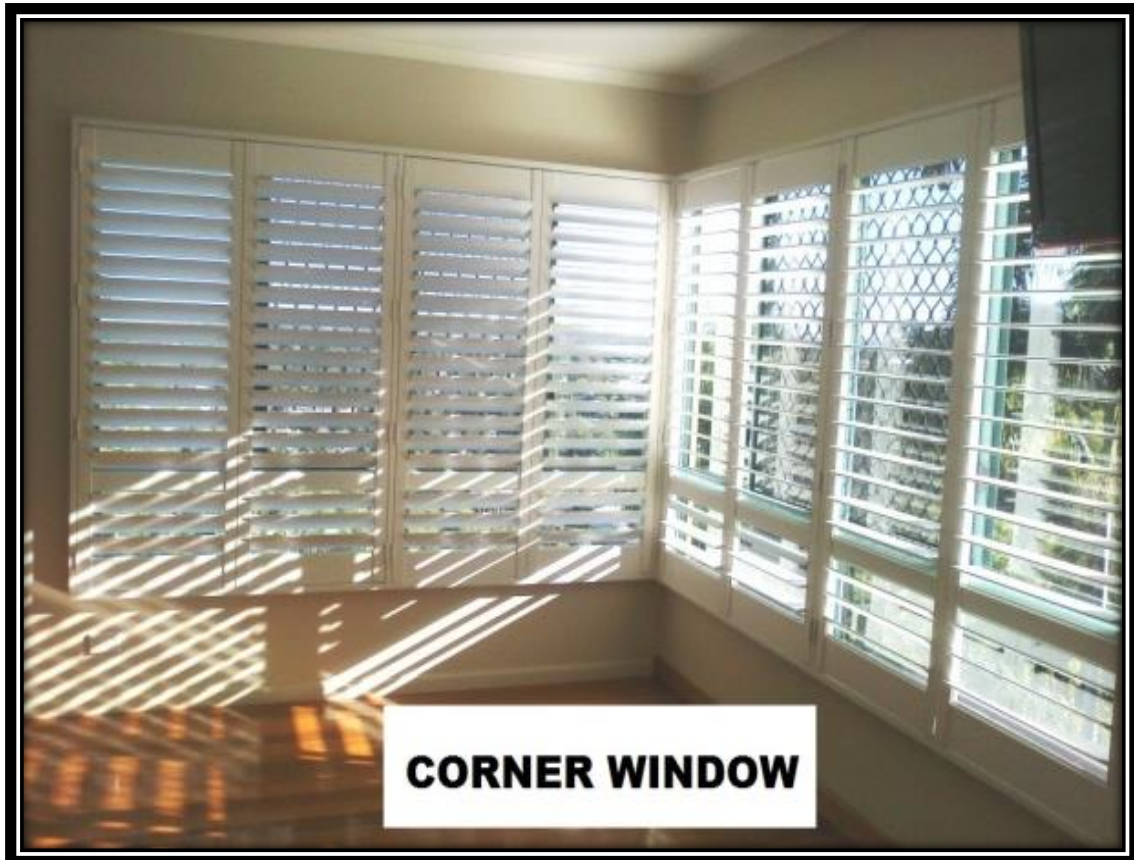

Corner Post

9.3 Measuring Guide for Bay and Corner Windows

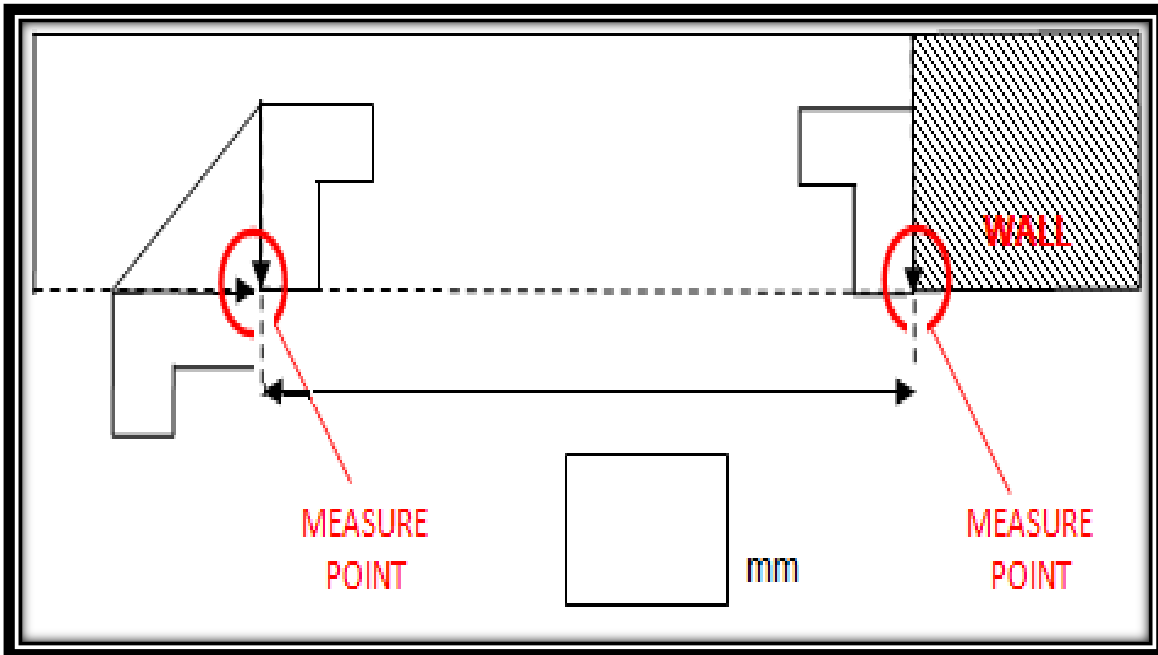

Examples of Frame Position

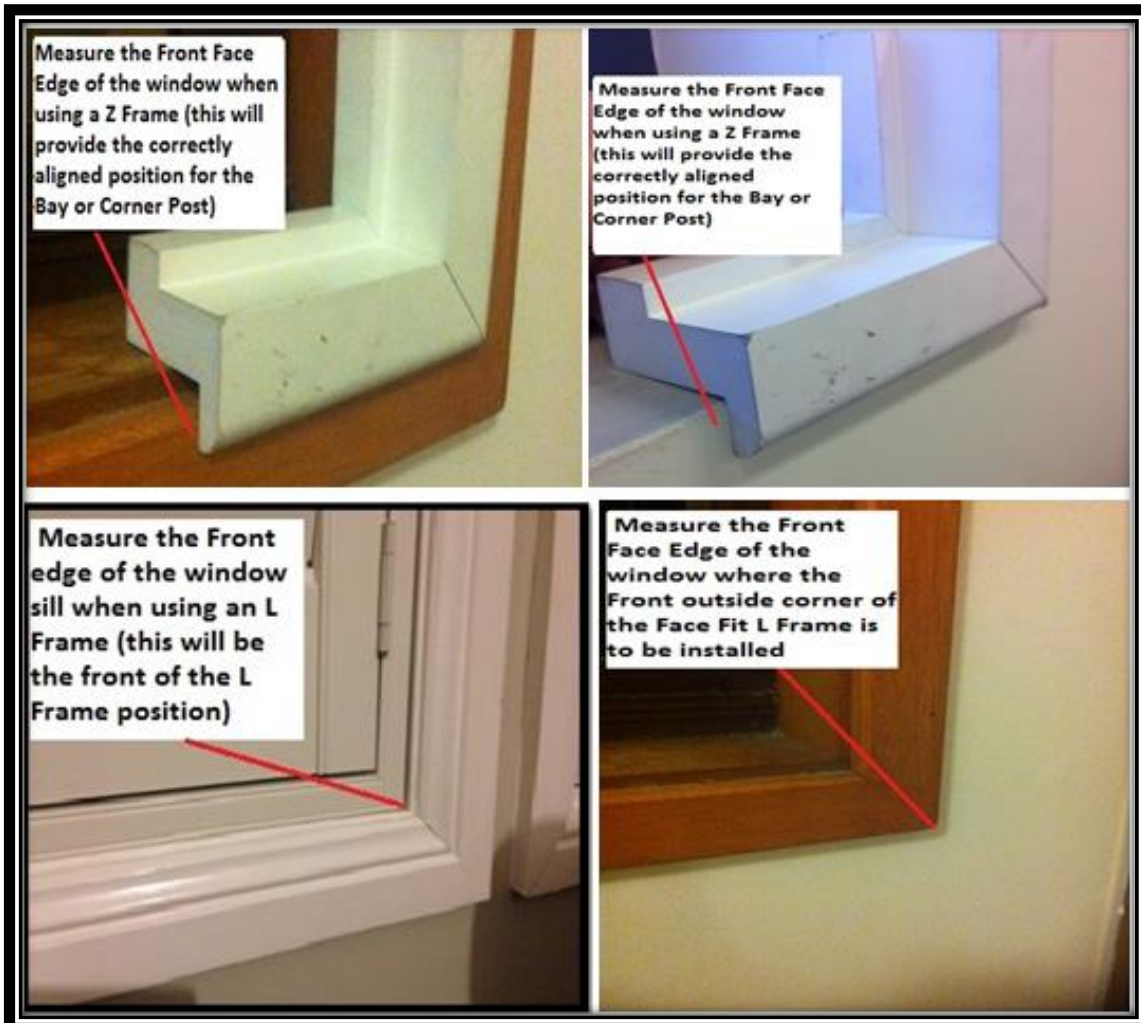

*See Glossary and Reference Charts at the end of this manual for more detailed information

9.4 Diagrams

Diagram Templates are available that can be used to submit the drawings and measurements for the *most common* types of windows. This does not include every possible option as every window can be different. For options that are not included a specially drawn diagram will need created and supplied. Drawings must be emailed as a Word document with your order. We cannot accept faxed copies.

Diagram Templates are listed in the Glossary. Please email salesupport@pacificwholesale.com.au if you require an electronic version of a Shutter Diagram Order Form.

9.5 Example of Specific Diagrams

Following is an example of one of the diagrams. It is suitable for Recess Fit L Frame and for Z frame;

Box Window Inside Mount (4 T Posts)

Line Item #	
-------------	--

MUST SUPPLY FRONT FACE OF RECESS MEASUREMENTS

- The Layout Code **must match** the Layout Code on the Order Form! Note "C" for Corner Post
- The combined 3 measurements must equal the "Gross Opening Width" on the Order Form.

PLEASE NOTE: When ordering Inside mount or Outside mount only provide the Front Edge Window Measurements (including the architrave if the architrave effects the position of the frame).

	Quantity	1st T Post (mm)	2nd T Post (mm)	3rd T Post (mm)	4th T Post (mm)
T Post					

Layout Code:	
--------------	--

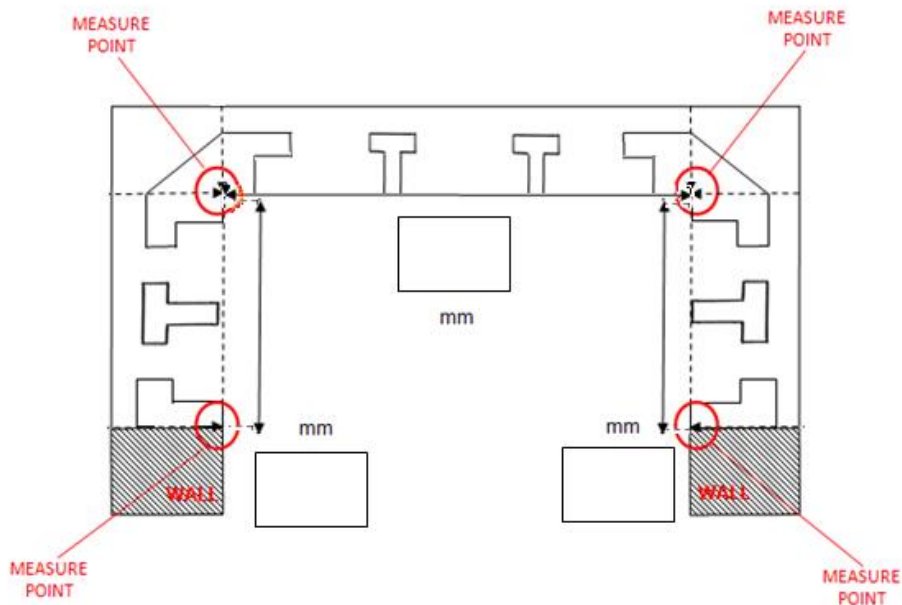

*See Glossary and Reference Charts at the end of this manual for more detailed information

9.6 Shaped Shutters

Shaped Shutters Templates and Drawings

Shaped Shutters can be a great option for covering uniquely shaped windows or cut outs in walls. Shaped shutters will require either*:

- A traced Template for curved shapes.
- A line Drawing with angles for straight line shapes.
- Before shapes are manufactured, the factory will supply drawings, which must be approved via email. This ensures the shape will be made to correct size.

Drawing Requirements

- All measurements included for straight lines and all angles in degrees (must be the same measurements as stated on the Order Form e.g. Gross Opening Width and Gross Opening Drop).
- Clear Scanned Drawings ONLY (we will not accept faxed drawings).
- Layout code on shape.
- Customer name and Order Form line item number written on the drawing.

Drawing Example:

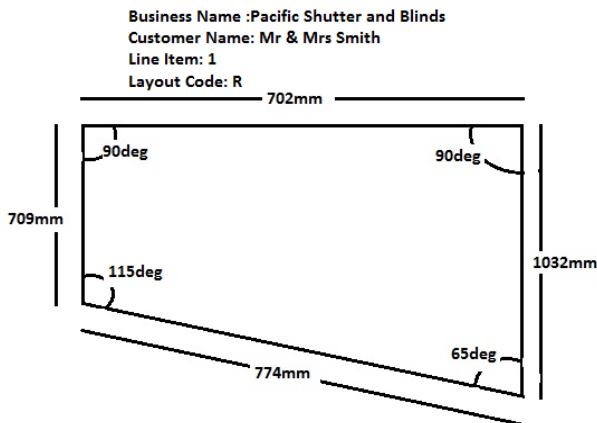

Template Requirements*

- Template cut to the correct size and shape of the window (must be the same measurements as stated on the Order Form e.g. Gross Opening Width and Gross Opening Drop).
- All measurements written on the template.
- Louvre Blade Design e.g. Standard Arch or Sunburst Arch.
- Customer's name and Order Form line item number written on the template.
- The received templates are posted to the factory overseas and must be able to be rolled neatly into a cylinder for posting.

Suggested template materials to trace on:

- Clear, thick plastic that won't stretch
- Corrugated Cardboard
- Thin Cardboard/Paper
- A template MUST be provided on a material suitable to be rolled up neatly

*See Glossary and Reference Charts at the end of this manual for more detailed information

Tracing a Window to create a Template

1. Tracing the Window



2. Template Example Required

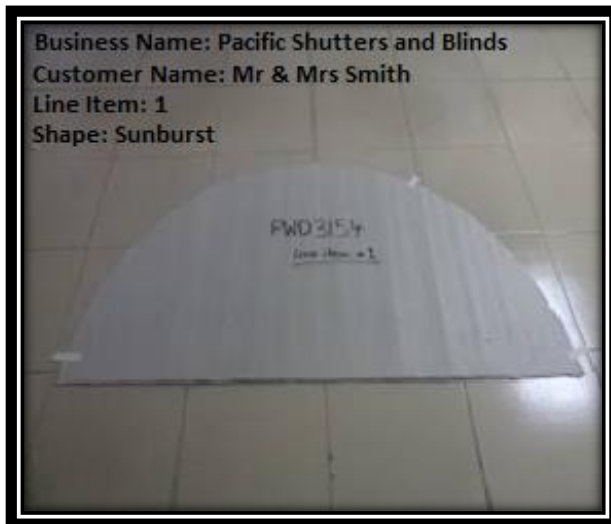

Shaped Shutters Gallery



*See Glossary and Reference Charts at the end of this manual for more detailed information

Shape Shutter Examples

Following are some examples of shaped shutters that can be manufactured. Timber Shapes are available in painted and stained colours. Some laminations will be obvious on Stained finishes.

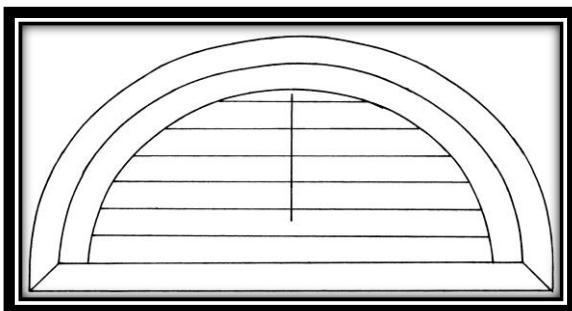
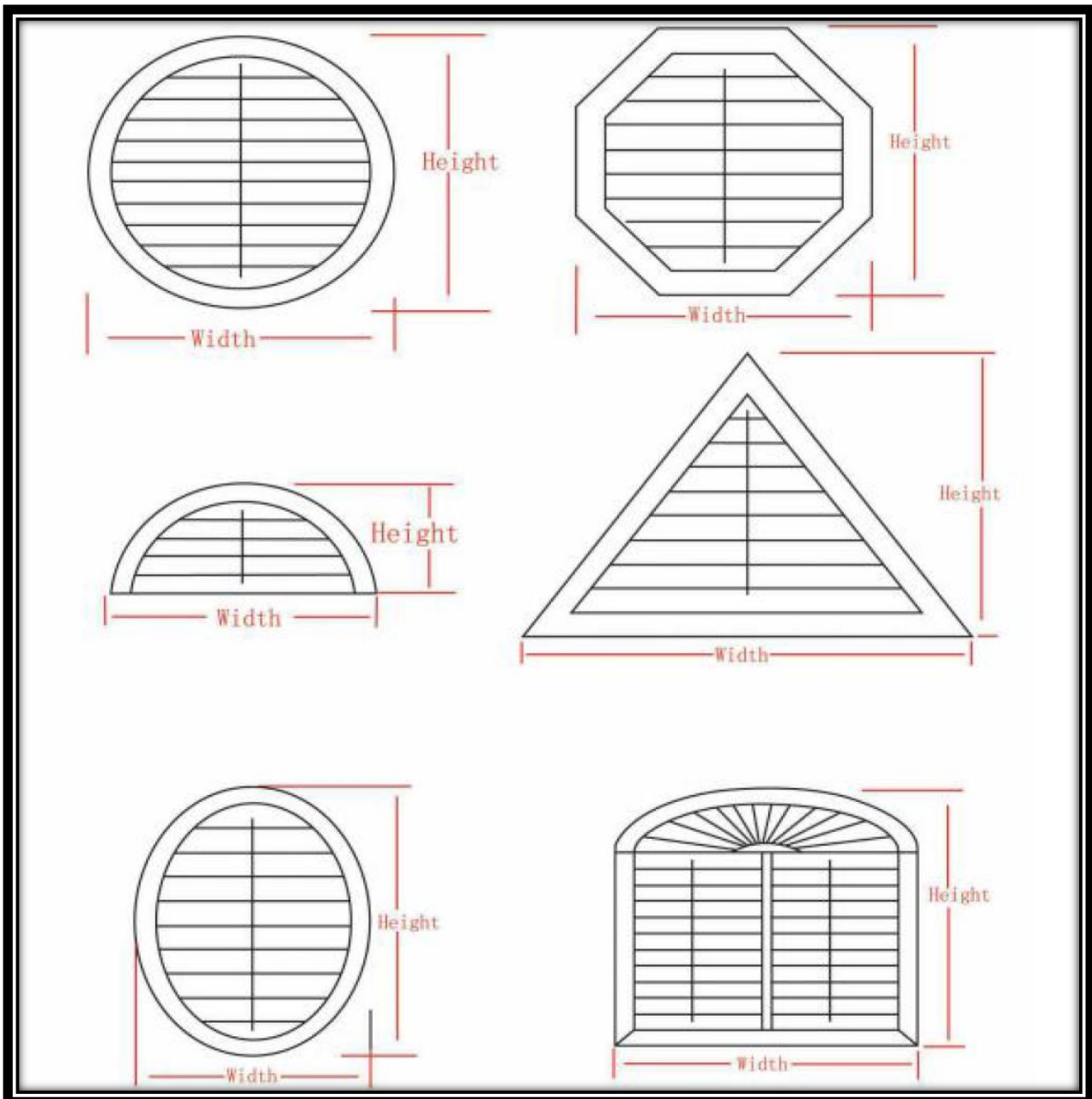

Standard Arch - with Centre Tilt Rod
(template required)

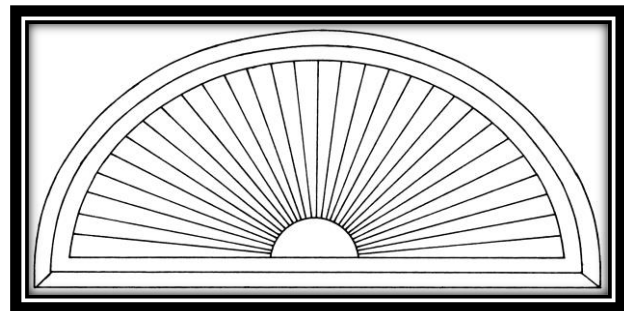

Sunburst Arch - no Tilt Rod available
(template required)

*See Glossary and Reference Charts at the end of this manual for more detailed information

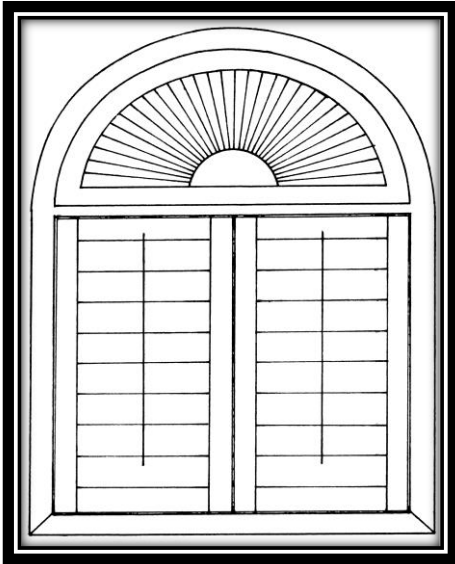

Sunburst Arch at top with Horizontal T-Post
(template required for arched section)

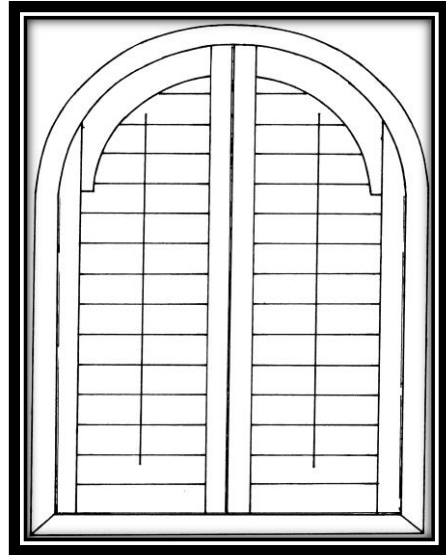

Arched Shutter - with Centre Tilt Rod
(template required for arched section)

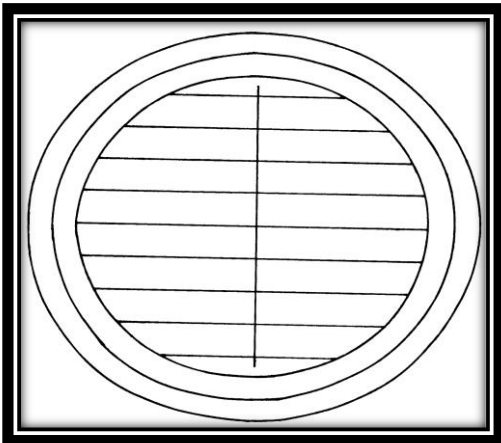

Circle Shape – with Centre Tilt Rod
(template required if not 100% symmetrical)

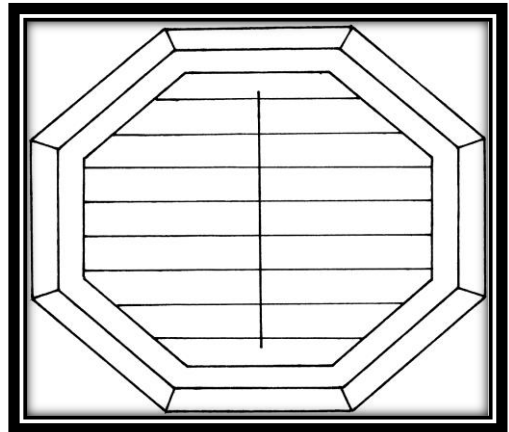

Octagon – with Centre Tilt Rod
(drawing required)

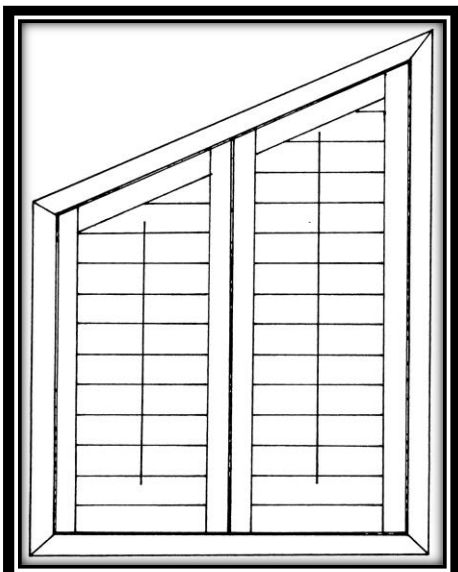

Left Rake – with Centre Tilt Rod
(drawing required)

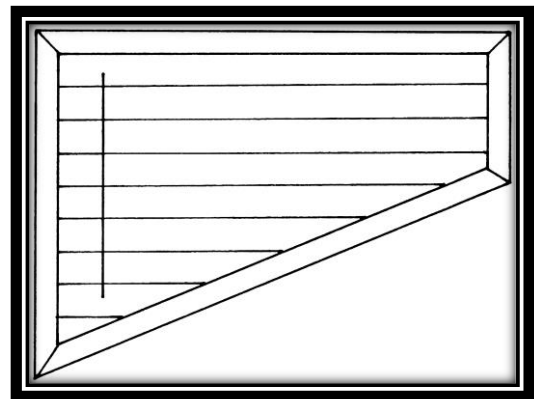

Angled Bottom Shape – with Off Set Tilt Rod
(can be Hidden), (drawing required)

*See Glossary and Reference Charts at the end of this manual for more detailed information

9.7 Door Cut Out

Door Cuts Outs in a shutter panel can be a great option for accessing an awkwardly placed door handle.

“Door Cut Out” – must be selected from the *Window Type* section of the Order Form and a completed drawing emailed in addition to the standard Order Form. Please email Pacific for the diagram. Note the shape of the cut-out and if a 6mm light block is required. Default is no light block.

The Crucial Measurements for Door Cut Outs are:

1. Bottom of L Frame to bottom edge of cut out
2. Bottom of L Frame to top edge of cut out
3. Depth of cut out
4. Panel Side for the Cut Out

Door Cut Outs require a longer lead time due to the specialised processes involved, the date of order begins from when the factory drawings have been approved (by the customer) and confirmed by the factory.

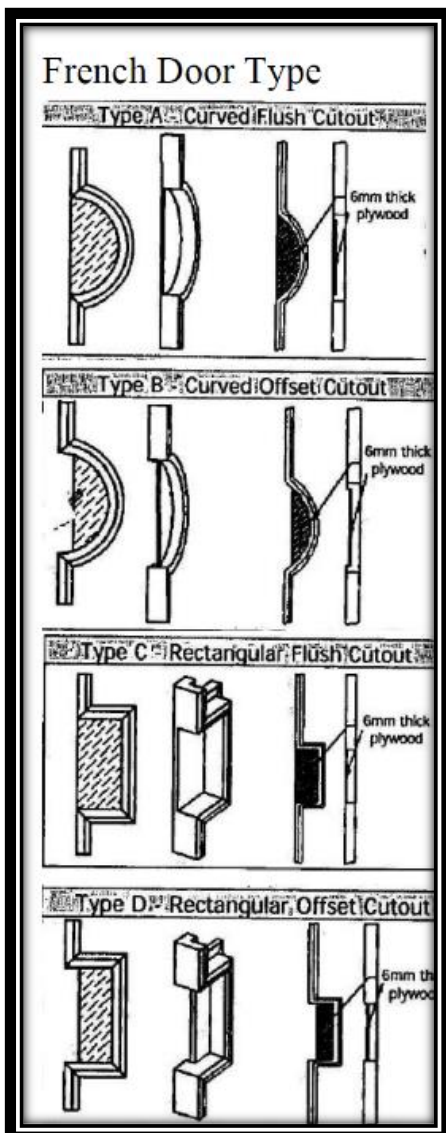

*See Glossary and Reference Charts at the end of this manual for more detailed information

9.8 Horizontal T Posts

Horizontal T Posts can be used in a window to separate or divide the panels at the top of a window to those panels at the bottom of a window when opening, a little like “barn doors”.

- A great option to accommodate obstacles like a lounge or even a bath situation etc.
- A Vertical T Post is recommended to support the Horizontal T Post if panels are to be used below the Horizontal T Post.
- A Filler Board can also be used above or below a Horizontal T Post instead of panels. Filler boards are attached with magnets so can be removed for cleaning. This is ideal to allow hinged panels to clear a tap, edge of a bath, or on the top of panels to clear a bulk head.



How to order Shutters with Horizontal T Posts

Panel Quantity = the total amount of individual panels in the entire opening

In the Midrail column - Please note the letters ‘HTP’ before providing the horizontal T Post measurement. This is always measured from the bottom of the opening, up to the middle of the T Post.

Layout code – the layout code is shown by working from the top, to bottom. Please list the layout code for the top section of panels, followed by the symbol ‘/’ (this represents the Horizontal T Post) followed by the layout code for the bottom section of panels.

Using this opening as an example 

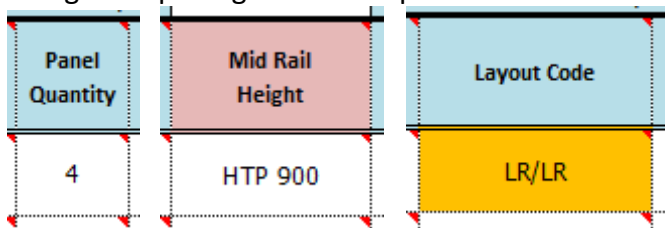

9.9 Motorised Shutters

Motorised shutters are ideal for internal openings that are hard to access, such as high up in stair wells. This system tilts 63mm or 89mm internal shutter blades by remote control.



The motor and remote are battery operated, with a range of approximately 30 meters. Each bank of blades has a unique motor to control the blades tilting up and down. The remote will control up to 14 motors (or banks of blades) individually, or all 14 in unison. Motor requires four AA batteries. Longevity depends on the quality of batteries and frequency of use.

The narrow motor simply attaches with double sided tape to the rear of the shutter. An unobtrusive white bracket is then fit to a single blade. The motor moves this bracket, the blade it is attached to, and all other blades that are joined to this blade by a tilt rod. Both Hidden Tilt and Rack & Pinion are can be used with a motor. Hidden tilts must be positioned on the opposite side to the motor. Motors should be positioned on the stile beside louvres at the most convenient height to change the battery.

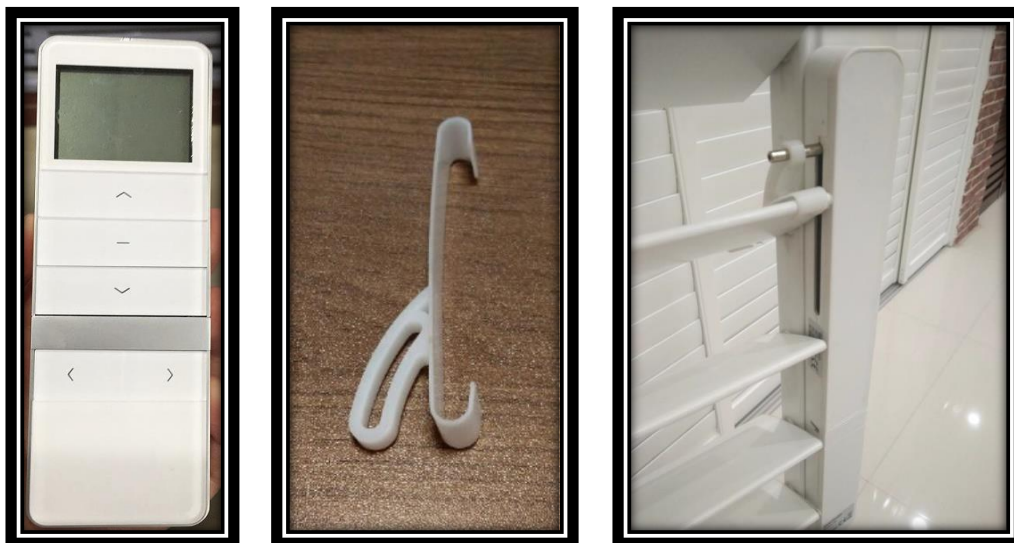

10. Hardware and Extra Timbers

10.1 Herman Joints (Hoffmann Keys)

Where possible frames will be fitted with double Herman Joints to firmly hold the mitred joints together to maintain squareness. This is essential for neat mitre joins and perfectly fitted panels.

10.2 Hinges

When Default or no Colour is selected, the Hinges will be supplied as per the default matching Hinge Colour list below;

COLOUR	HINGE COLOUR
Antique White (W140)	Antique White
Black Walnut (W920)	Black
Eggshell (W405)	Eggshell
Grey (W030)	Grey
Jasper (W498)	Jasper
Light Grey (W032)	Light Grey
Pure White (W190)	Pure White
Slate (W057)	Slate
White (W105)	White
Bright White	Bright White
Classic White	White
Snow White	Snow White
Super White	Snow White
Vanilla	Ivory
Ceylon	Ceylon
Earl Grey	Earl Grey
French White	French White
Infinite White	Infinite White
Polar White	Polar White
Quiet White	Quiet White
Snow Gum Grey	Snow Gum Grey
Snowy Mountains White	Snowy Mountains White
Barca Walnut	Barca Walnut

Royal Walnut	Royal Walnut
Colombia Walnut	Colombia Walnut
Shadow Chasing Walnut	Shadow Chasing Walnut

These Timber Stained Colours require the Hinge Colour to be selected;

Cedar Image Medium (W868)
 Maple (W893)
 Riva (W200)
 Walnut (W891)

COLOUR	SUGGESTED HINGE COLOUR
Cedar Image Medium (W868)	Antique Brass / Bronze
Maple (W893)	Antique Brass / Bronze
Riva (W200)	Brass
Walnut (W891)	Antique Brass / Bronze

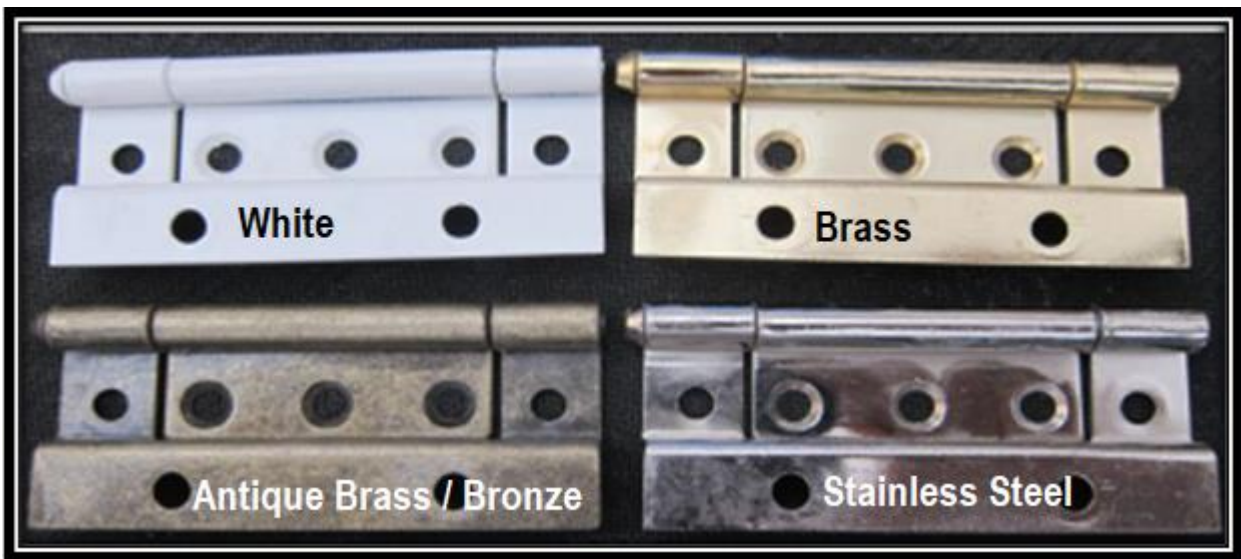

**Stainless Steel incurs additional cost.*

**Stainless Steel hinges are supplied in a 304 grade Stainless*

Flush Bolts

- * Surcharge Applies
- * Available to order on all mounting methods
- * Only available in Stainless colour. These cannot be colour matched to the shutter panels
- * When ordering with the Rack & Pinion Tiltrod, the bottom rail must be bigger than 115mm



10.3 Timber Extras

Listed are the standard Extras, available on the order form. Other sizes are available POA.

DESCRIPTION	SPECIFICATIONS
Light Stop	25mm x 30mm
	19mm x 6.35mm
	31.8mm x 9.5mm
Mounting Block	44.45mm x 25.4mm
	19mm x 19mm
Fascia	60mm x 9.5mm
	100mm x 9.5mm
	140mm x 9.5mm
Headboard	100mm x 19mm
	140mm x 19mm
	180mm x 19mm
	220mm x 20mm
U Channel	54.5mm x 60.3mm
	54.5mm x 40mm
Bullnose Z Frame	
Large Bullnose Z Frame	
Hanging Strip	30mm x 25.4mm
Small Face Fit L Frame	
Small L Frame	Small L Frame (Beaded) Small Flat L Frame
Medium/Large Face Fit L Frame	
Medium/Large L Frame	
Large Flat L Frame	
Medium Flat L Frame	
Z Sill Frame	
Large Z Frame	
Standard Z Frame	
T Post	

Item #	Quantity	Length	Material & Product	Extra's	Colour
1	2	1200	Timber Eco	Light Stop 31.8mm x 9.5mm	Pure White (W190)
2					
3					

*See Glossary and Reference Charts at the end of this manual for more detailed information

11. Sales Aids

We have introduced a range of swatches and sales aids that can be used by all sales people when promoting the Shutter range.

11.1 Swatches

Timber Eco

Painted & Stained

\$POA per set



Timber Laminated

\$POA per set



11.2 Shutter Sample

Painted, Stained or Laminated available
280mm x 470mm

\$POA each

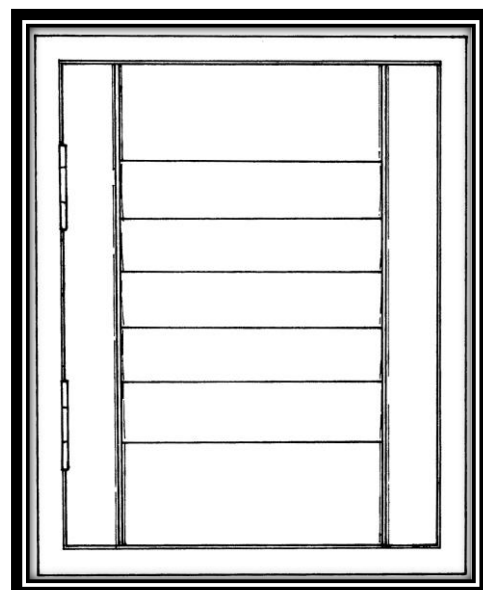

*See Glossary and Reference Charts at the end of this manual for more detailed information

11.3 Timber Shutter Case

Includes:

1 x Timber Painted Sample Panel with Hidden Tiltrod

1 x Timber Stained Sample Panel with Rack & Pinion Tiltrod

Colour Samples

Frame Samples

\$POA each



An electronic Sales Aids order form is available, please email salesupport@pacificwholesale.com.au and request a Sample Swatches order form to be emailed today.

*See Glossary and Reference Charts at the end of this manual for more detailed information

12. Shutter Remake Process

In the event of Shutter Panels, Frames or Parts being received damaged the following information must be emailed to shutterorders@pacificwholesale.com.au

1. Copy of the original order form.
2. A new order form, clearly showing the shutter(s) that need remaking. Please specify that the order is a **remake** – failure to do so may result in the original order being placed as a new order at full charge.
3. A detailed description specifying exactly what the concern is and exactly what panels/frames etc. need remaking. Failure to clearly specify this information may result in a longer lead time. More often than not the fastest solution to rectify a concern is to order the parts only required e.g. Louvre Blades and Pins, Framing Section etc.
4. Supporting photographs illustrating any concerns. For example – if the panels/frames supplied were too short, photographs to show a tape measure being held against the panels/frames, to clearly illustrate the size they were supplied at are required, as shown below.



Or if the panel is believed to be bowed then a *photo must be provided of the panel lying down on a flat surface* as shown below.



*See Glossary and Reference Charts at the end of this manual for more detailed information

13. Care and Maintenance

Cleaning and Care

The surfaces of Timber Eco Shutters will collect a layer of dust over time. Normal and regular dusting with a soft damp cloth will remove this build up.

If further cleaning is required, wash with mild soap (mild household dishwashing liquid), water (damp only) and a soft cloth. Ensure the surfaces are dried with a soft cloth.

For stubborn dirt and stains use a mild, water-based household cleaner.

Should Timber Eco shutters be caught in a rain shower and become wet, all water must be dried as soon as possible. A hair-drier on a cold setting can be used to blow any water out from between the stile and blades and a soft towel used to ensure no water is left between and around the frame and panel.

Pencil-like marks can form on light coloured painted shutters due to some metals coming into contact with the paint, such as rings and other jewellery. These marks are removed with a small amount of Eucalyptus Oil on a soft cloth.

CAUTION:

Never use thinners, harsh cloths, harsh abrasives, chlorine or ammonia-based chemicals or cleaners on Timber Eco Shutters surfaces as they may affect the surface appearance and longevity.

14. Shutter Questions & Answers

Q: Panel sizes?

A: Panel sizes will vary depending on the blade size chosen (63/89/114mm), and also the chosen Mounting Method/Mode of Operation etc. Refer to the Shutter Reference Chart following.

Q: Should Timber Eco be used in wet areas?

A: We recommend using Fauxwood for wet areas such as bathrooms.

Q: Will Timber Eco shutters be ruined if they get wet?

Timber Eco Shutters are moisture resistant, not water proof. They are able to withstand normal levels atmospheric humidity. Should Timber Eco Shutters become wet, they should be dried as soon as possible and not allowed prolonged, or repeated contact with water. If water is able to penetrate the timber, the finish may be affected. If shutters are likely to become wet or exposed to moisture in excess of normal atmospheric levels (such as a steamy bathroom, or rain through an open window), please order Fauxwood, as water damage is not covered by the Timber Eco warranty.

Q: What deductions are taken for inside mount?

A: For Hinged Panels in frames the deduction for inside mount is 3mm in the width and also the drop. Refer to [Framing for Hinged Panels](#)

Q: Can Bullnose Z Frame be used for outside mount?

A: No, Z Frames including the Bullnose Z Frame are only for reveal fit applications. Refer page [Mounting Methods](#)

Q: Do I need framing for my shutters?

A: Ideally framing should always be ordered and used on shutters as a secure anchorage for the panels, for reducing light penetration, and to assist in compensating for out of square openings.

Q: When do I need a T Post?

A: When more than one panel is used in a window opening and the T Post is used to hinge a panel. Refer to [T Posts](#)

Q: Do I need to supply a diagram for Bays or Corner windows?

A: Yes, if the window is to be ordered as one complete opening. Using either a Bay Post (135 degree), or Corner Post (90 degree), this post becomes an integral part of the layout code please see [Example of Specific Diagrams](#)

Q: What width is the mid rail?

A: TIMBER eco Mid rails are 76.2mm in width (depth).

Q: Why can't my mid rail be at the height I have requested?

A: If the midrail can't move up or down 40mm, order the Mid Rail location as "Critical Mid Rail" in the Special Comments, as the factory has a Mid Rail Adjustment allowance of 40mm up or down, if "Critical Mid rail" has not been specified in the Special Comments.

Every effort will be made to have the mid rail placed in the exact position requested but there can be some variances, depending on the height of the panels. *Refer to [Mid Rail](#)*

Q: Why can't I have two mid rails critical?

A: Shutters over 2500mm high will require two mid rails, however only one of those mid rails can be specified as "Critical Mid rail" – please note this on the order form, in the Special Comments. Every effort will be made to have the "Critical Mid rail" placed in the exact position requested, however the second mid rail cannot be Critical as the overlaps and increments for every blade location have to be exact, so the second mid rail height will vary depending on the height of the panel and the number of blades. *Refer to [Mid Rail](#)*

Q: Can I have an uneven number of panels for a bi fold?

A: No, Bi folds must always have an even number to operate *refer to [Bi Fold Panels](#)*

Q: Do I need a bottom track on Bi Fold or Sliding Shutters?

A: Yes, they should always have a bottom track for efficient operation and longevity however Timber Sliders can also use a Floor Guide if suitable. Tracks are strongly advised. *Refer to [Tracking for Bi Fold Panels](#)*

Q: Do I need a template for shaped shutters?

A: Yes, if the shape is curved, the shape of the opening must be accurately traced onto a template suitable to roll to post. If the shape is angles with straight lines only, a template is not required. Instead a drawing showing the measurements and angles is required. *Refer to [Shaped Shutters Templates and Drawings](#)*

Q: Do I need pictures of faulty goods?

A: Yes, we need detailed photos. These are vital communication aids which the factory requires to support your claim, and to help to establish what needs to be replaced in order to achieve a quick resolution *refer to [Shutter Remake Process](#)*

Q: Do you need the goods back once we have replaced them?

A: Not unless requested by Pacific.

Q: What's my lead time on shutters?

A: Normal lead time is between 5 and 8 weeks from order confirmation (i.e. once all information received on the order form is correct and complete without further questions). Longer lead times can occur during and after holiday periods (such as Christmas and Chinese New Year) and due to extenuating or unusual circumstances such as shipping delays, back-logs, supply shortages etc.

15. Glossary

Angled Windows Except Bay, Box and Corners	Windows with angles other than 135o and 90o should be ordered as separate individual windows, on separate line items and do not require a supporting diagram. The factory will make individual deductions for each separate window. In this case, order any extra timber from which to infill the angles between the openings in the Extra’s area. Note in the comments on the order that these items are side by side.
Apple Software	If using an Apple computer, please use Excel for Mac (available online) to be able to see the drop-down options on the order form.
Bay Window Measuring Guide	<p>The WIDTH of Bay Window arrangements will decrease, the further out they are fitted from the windows. Therefore, it is vital that the measurements given are taken at the correct depth. This varies if the opening has an architrave that will affect the position of the frame.</p> <p>RECESS FIT L FRAME – Measure where you will position the front edge of the frame, which is usually the front edge of the reveal. Use template “Bay Window – Inside Mount”.</p> <p>Z FRAME NO ARCHITRAVE – Measure where you will position the back face of the overlapping part of the frame, which is the front of the reveal. Use template “Bay Window – Inside Mount”.</p> <p>Z FRAME WITH ARCHITRAVE – Measure where you will position the back face of the overlapping part of the frame, which is on the face surface of the architrave, from the edge of the reveal to the opposite edge of the reveal. Use template “Bay Window – Inside Mount”.</p> <p>FF L FRAME – Measure where you will position the base of the frame, which is the front edge of the architrave, or (if no architrave) the wall. Use template “Bay Window – Outside Mount”.</p>
Bay Window Ordering	The standard order form must have “Gross Opening Width” measurements supplied as a combined total of all 3 separate bay section measurements (e.g. 600mm + 1200mm + 600mm = 2400mm “Gross Opening Width”). “Bay Window” must be Selected in the Window Type Column on the order form. Include all Bay and T Posts in the Layout code. A ‘B’ in the Layout Code represents a Bay Post. Include T posts but not Bay Window posts in the order form column for “T Post Quantity” and their position(s).
Bay Window Template	Templates should have the 3 separate section measurements and location of Bay and any T Posts shown. Please see the measuring guide (above) and supply the correct Bay Window Template. These are available by email from PACIFIC, if you do not have them on hand. If the opening requires T Posts for hinging extra panels, check the list below for the availability of a special diagram. If not available, draw these on a diagram.
Bay Window Template List – Inside Mount	<p>Bay Window</p> <p>Bay Window Inside Mount (1 Bay – 1 T Post)</p> <p>Bay Window Inside Mount (1 Bay – 2 T Post)</p> <p>Bay Window Inside Mount (1 Bay Post)</p> <p>Bay Window Inside Mount (1 T Post)</p> <p>Bay Window Inside Mount (2 T Posts)</p> <p>Bay Window Inside Mount (3 T Posts)</p> <p>Bay Window Inside Mount (4 T Posts)</p> <p>Bay Window Inside Mount</p> <p>Bay Window Horizontal T Post</p>

Bay Window Template List – Outside Mount	Bay Window Outside Mount (1 Bay – 1 T Post) Bay Window Outside Mount (1 Bay – 2 T Post) Bay Window Outside Mount (1 Bay Post) Bay Window Outside Mount (1 T Post) Bay Window Outside Mount (2 T Posts) Bay Window Outside Mount (3 T Posts) Bay Window Outside Mount (4 T Posts) Bay Window Outside Mount Bay Window Horizontal T Post
Bifold Panels	<p>When ordering BiFold shutters, an even number of panels folding each way is essential. For Example; if there were 4 panels, 2 panels could stack each way, or all 4 to one side. If there were 6 panels, they need to all stack one way, or 2 panels to one side and 4 panels to the other side. The front of the panel is the side that the panels fold towards. The blades close up on this side and the hidden tilt is on the back unless requested otherwise. The narrower the panels (the more panels in the opening), the less they will protrude into the room when they are folded at approximately 90 degrees to the wall/architrave. BiFold Panels will not fold back 180 degrees to lay flat on a wall. By Default, Bifold panels are made with Rabbet Stiles where the panels meet to ensure the light gaps are kept to a minimum.</p> <p>If ordering BiFolds as a room divider, extra Fascia and large light blocks (for on the front edge of sideboards) may need to be ordered for the back side of the shutters in the Extra's area. Note where you want the track to be positioned, if not wanted at the front edge of the headboard.</p>
Bifold Framework	<p>Default is a 100mm Headboard and Side Boards. On request in the Comments area 140mm, 180mm or 220mm depths are available. Side Frames/ Boards are recommended on all Bifolding Panels. Please select “YES” in the “Left & Right” Framing Columns on the order form. When Side Frames/ Boards are selected a Light Block to be attached to the face edge of the SB will be supplied along with SB Mounting Blocks.</p> <p>If NO Side Frames/Boards are selected but a Light Block is required on each side, please select “Light Stop” in the “Left & Right” Framing Columns on the order form.</p> <p>The headboard and track will not exceed 4200mm in length, sizes ordered over 4200mm will be in two sections. The track will be divided according to the layout and the division in the headboard and tracks will be offset to provide a smoother operation at the join.</p>
Bifold Outside Mount	<p>Outside of Frame measurement MUST be supplied for Outside Fit, this must be to the top of the 19mm thick Headboard and include 20mm each side allowance for Sideboards on the left and right sides of the opening, if these are ordered. No deductions outside the frame are made for Face Fit applications, and it is assumed that there is space for 12mm returns on the fascia outside the width given.</p>
Bifold Reveal Fit	<p>For IN, unless otherwise stated, a deduction will be made for a Headboard, and a Headboard will be supplied. If no Headboard is required, please make this clear on the order form. Panels will not be the correct height if the supplied HB is not used.</p> <p>If fitting the track directly to a ceiling or reveal, allow 54mm clearance from the front of the top track (front edge of the reveal) for the Bifold panel to pivot. This assumes there is sufficient recess space for the blades.</p> <p>When ordering, the Panel Quantity must match the Layout Code e.g; 2 panels = LL; 4 panels = LLRR.</p> <p>If ordered IN, Fascia is supplied without returns unless otherwise requested.</p>

Bifold Tilt Rod	It is recommended that Hidden Tilt Rod, or Rack & Pinion are ordered for all Bi Fold panels. However, if a Centre Tilt Rod is required it will be offset by 8mm to ensure the panels fold back evenly.
Bifold Tracks	Bi Fold Shutters must have both top and bottom tracks fitted to operate properly. The headboard and track will not exceed 4200mm in length, sizes ordered over 4200mm will be in two sections. The track will be divided according to the layout and the division in the headboard and tracks will be offset to provide a smoother operation at the join. Bi Fold Hardware i.e. wheels, top & bottom pivots, bumpers will be supplied. Bi Folds that have a centre opening layout i.e. LLRR – will be supplied with two independent top track stopper blocks. White toned panels are supplied with White bottom tracks. Stained panels with Brown bottom tracks, except Riva, Grey and Black toned panels will be supplied with Silver bottom tracks. Variations should be requested in the Notes area on the order form.
Box Window	See Corner Window for most information. Templates are below.
Box Window Template List	<p>Box Window</p> <p>Box Window Inside Mount (1 T Post)</p> <p>Box Window Inside Mount (2 T Posts)</p> <p>Box Window Inside Mount (3 T Posts)</p> <p>Box Window Inside Mount (4 T Posts)</p> <p>Box Window Inside Mount</p> <p>Box Window Outside Mount (1 T Post)</p> <p>Box Window Outside Mount (2 T Posts)</p> <p>Box Window Outside Mount (3 T Posts)</p> <p>Box Window Outside Mount (4 T Posts)</p> <p>Box Window Outside Mount</p>
Calculation Column on Order Form	The blue Calculation cells labelled “Large Size Panel” and “m2” are for your information only and can’t be changed.
Corner and Box Window Measuring Guide	<p>The WIDTH of Corner or Box Window arrangements decrease the further out they are fitted from the windows. Therefore, it is vital that the measurements given are taken at the correct depth. This varies if the opening has an architrave that will affect the position of the frame.</p> <p>RECESS FIT L FRAME – Measure where you will position the front edge of the frame, which is usually the front edge of the reveal. Use template “Corner Window – Inside Mount” or Box Window – Inside Mount.</p> <p>Z FRAME NO ARCHITRAVE – Measure where you will position the back face of the overlapping part of the frame, which is the front of the reveal. Use template “Corner Window – Inside Mount” or Box Window – Inside Mount.</p> <p>Z FRAME WITH ARCHITRAVE – Measure where you will position the back face of the overlapping part of the frame, which is at the face surface of the architrave, from the edge of the reveal to the opposite edge of the reveal. Use template “Corner Window – Inside Mount” or Box Window – Inside Mount.</p> <p>FF L FRAME – Measure where you will position the base of the frame, which is the front edge of the architrave, or (if no architrave) the wall. Use template “Corner Window – Outside Mount” or Box Window – Outside Mount.</p>

Corner and Box Window Ordering	<p>The standard order form must have “Gross Opening Width” measurements supplied as a combined total of all 2 or 3 separate corner section measurements e.g. 600mm + 1200mm + 600mm = 2400mm “Gross Opening Width”.</p> <p>“Corner Window” must be Selected in the Window type column on the order form. Include all T Posts and Corner Posts in the Layout code. Using a ‘C’ in the Layout Code represents a 90o Post. Include T posts, but not Bay Window posts in the order form column T Post Quantity, and the position in the adjacent columns.</p>
Corner or Box Window Template	<p>Please see the Corner and Box Window Measuring Guide in this glossary. Use the correct Corner or Box Window Template. These are available by email from PACIFIC if you do not have them on hand. If the opening is 3 sided (a Box Window), check the list for the availability of a special diagram. If not available, add the third side to a corner diagram by drawing it on the template. If the opening requires T Posts for hinging extra panels, check the list for the availability of a special diagram. If not available, draw these on a diagram.</p>
Corner Window Template List	<p>Corner Window</p> <p>Corner Window Inside Mount (1 T Post)</p> <p>Corner Window Inside Mount (2 T Posts)</p> <p>Corner Window Inside Mount (3 T Posts)</p> <p>Corner Window Inside Mount (4 T Posts)</p> <p>Corner Window Inside Mount</p> <p>Corner Window Outside Mount (1 T Post)</p> <p>Corner Window Outside Mount (2 T Posts)</p> <p>Corner Window Outside Mount (3 T Posts)</p> <p>Corner Window Outside Mount (4 T Posts)</p> <p>Corner Window Outside Mount (5 T Posts)</p> <p>Corner Window Outside Mount (6 T Posts)</p> <p>Corner Window Outside Mount</p>
Critical Mid Rail	<p>If the mid rail can’t move up or down half a blade width, mark the item as “Critical Mid Rail” in Standard Special Comments, corresponding to the appropriate Line Item on the order form. If there is some leeway, please advise in the Special Comments notes area. For example, if the window mullion to be covered is 30mm deep, and the Mid Rail is 76mm deep, then the Mid Rail could be positioned up 23mm, or down 23mm and still cover the mullion. Make a note in the comments area for this item “MR can move +/- 23mm”. This flexibility could allow the designer to deliver a more balanced panel, or to match blade heights with another panel that is side by side.</p>
Custom Colours	<p>Our factory has the current Dulux Fandek selector on hand and will match to this. The closest match possible will be made. Lighting, gloss level, texture and coating application methods all contribute to the appearance of paint colour. Even the closest match may appear different in comparison to a different surface.</p>
Double Hinged Panels	<p>Double Hinged Panels (Hinged Bi Fold) can be a good solution for windows where a fixture such as a tap prevents a wider single panel from opening fully, or where the customer wants the panels to fold back off the window, without any frames obstructing the view or access to the window.</p> <p>If fitted in a Z or FF Frame, the panels will fold back to the wall. Some customers want their shutters to fold off the opening to preserve a view, or to be able to lift out sliding windows to clean them. This mounting method will facilitate this.</p> <p>Caution should be exercised as the cumulative weight of the two panels must be taken into account. For this reason, there are panel width restrictions. Double Hinged Panels cannot be made wider than the Double Hinged Standard Maximum sizes as shown in the Shutter Range & Mounting Methods Reference Charts. This type of shutter may need to be lifted slightly on and off its frame or window sill, therefore ordering a Double Hinged without a bottom frame is not recommended. Bumper Stoppers will be supplied to support panels in the frame. The maximum number of Double Hinged panels attached together is two. When ordering the Panel Quantity must match the Layout Code.</p>

Face Fit	When ordering Face (outside) Fit shutters, use frame samples to ensure the blades and tilt rods clear any impediments such as louvers, handles and so on. If the outside of the frame is to be mounted less than 70mm from the edge of the reveal, the blades will be entirely in front of the recess, therefore the blades may open into any clear space in the recess, reducing the depth of frame required.
Face Fit Depth Required	If there is no clear reveal that the blades can open into, with Hidden tilt rods, measured from the front edge of the frame, 89mm blades need 62mm; 63mm blades need 50mm and 114mm blades need 75mm Frame depth. This depth can be reduced by approx. 4mm if a Rack and Pinion, Centre or Offset tilt is ordered.
Fixed with Lightstop Beading	To order Fixed with Lightstop Beading, fill in the order form except the columns from Layout Code to Bottom Frame. Select the "Panels Fixed with Lightstop Beading Front & Back" option on one of this item's Standard Special Comments columns. As openings without windows are frequently significantly out of square, or not straight, the beading will be supplied longer than the opening size to allow the installer to trim for a perfect fit. If exact sizes are required, list the specific lengths of beading in the Special Comments.
Fixed with Magnets	To order the entire opening Fixed with Magnets, complete the order form as for hinged panels and select the "Panels Fixed with Magnets & Catches" option on one of this item's Standard Special Comments columns. To order specific panels to be fixed with magnets, complete the order form as for hinged panels and note in the Special Comments which panel(s) numbered from left to right that should be Fixed with Magnets and Catches. Width and drop guidelines are the same as hinged panels, please see Shutter Range & Mounting Methods Reference Charts. Fix the panel securely if the magnet fixed panel will be subjected to wind behind it, or if situated where a child could pull the panel onto itself.
Fixed with U Channel	Fixed with U Channels are suitable for Recess Fit only. When ordering, there is NO Layout Code Required; however, the Panel Quantity must be specified. Where more than one panel is required in an opening, Rabbet stiles are used to reduce any light gaps between panels. Astragal Stiles (D moulds) are not suitable. Light Stop is supplied for the front side of the panel, when selected in the "Left & Right" Framing Columns on the order form. Extra Light Stop can be ordered for the back. This needs to be requested in the "Extras" section on the order form. If light stop is fitted to the panels, the panels will not be removeable. This is ideal if the arrangement is between two rooms, used as a room divider, or are situated where the panel could be knocked up and out of its frame by accident. Width Deduction is 1mm off the width of the U Channels and 3mm off the width of the panel.
Flat Stile	Specify Flat Stiles in Stile drop box on order form to receive stiles without a bead (groove).
Flush Bolt	Available to be fitted to Bifold Panels to assist avoiding the panels blowing into a zig-zag. Usually fitted one per pair at the bottom of the stile. Flush Bolts are required for Free-Sliding Bifolds. Use the Order Form Comments section to order this option. Surcharge applies.
Hanging Strip	For this application the Hanging Strip is mounted to the sides of the reveal, behind the panels. L shaped Hinges are placed on the face side of the Hanging Strip, which allows the Hanging Strip to act as a light block. A Light Stop is used at the top and bottom of the window frame, with the magnet catches attached, to secure the panel and to block light.
Hinge Number	The number of hinges for each item is calculated outside the order form in column AU. This is handy if quoting Stainless Steel hinges.

Horizontal T Post Template List	Horizontal T Post Horizontal T Post with Filler Board
Location	Specifying the Location on the order form helps the installer to distribute boxes into the correct room. This option also advises the shutter designer that several items are in the same room. Some items of a similar drop may be made with different blade numbers and rail sizes as they fall either side of a guideline. To prevent this, please advise in the notes section if any items are “side by side”. If they are side by side but have significantly different opening heights, note if they line up at the top or bottom.
Mid Rail Position	Every effort will be made to have the mid rail placed in the exact position requested, but there can be some variances depending on the height of the panels. A well- balanced panel ideally has rails of equal depth, or smaller top rails than the bottom rail. This can mean that the Mid Rail may be moved up or down, up to half a blade width. If the midrail can’t move up or down half a blade width, mark the item as “Critical Mid Rail” in Standard Special Comments, corresponding to the appropriate Line Item on the order form. If there is some leeway, please see “Critical Mid Rail” above
Moisture Resistance	TIMBER eco shutters are moisture resistant, therefore able to withstand normal levels of atmospheric moisture in humid climates. Although tough and hard wearing, they are not water proof and therefore not recommended for windows that are specifically in wet areas, or rooms that can create a lot of condensation e.g. laundries, bathrooms or kitchens.
No Frame at The Bottom	It is best to order Framed Shutters with full four-sided framing, however exceptions to this may apply if the side frames run to the floor. Without a bottom frame, pairs of panels will not have a frame on which to mount bottom magnet catches. Panels may not sit perfectly aligned without bottom catches, or light stops
Numbering Panels	Within an Item, panels are numbered from left to right to identify them. For example, in a four panel arrangement, the left hand panel is Panel 1; next to it on its right is Panel 2; then Panel 3 and the extreme right hand panel is Panel 4. Use these panel numbers to clearly identify any Special Comments or requirements for particular panels. If numbering Tier on Tier Panels, please number the top panels left to right, then the bottom panels left to right
Order Exceeds 15 Items	If your order exceeds 15 Items, enter Items 16 and over on the 2 nd Shutters tab across the bottom of the order form – this tab is labelled as ‘Shutters Page 2’
Order Form Help	There are a number of cells that have helpful comments embedded. Hold your cursor over the cell to read these.
Paulownia	Paulownia (<i>Paulownia tomentosa</i>) is used in applications where a lightweight, yet strong timber is needed. It is perfect for plantation shutters due to its resistance to moisture, straight grain, light weight, durability, high silica content, decay resistance and because it takes a wide variety of glues, stains, and finishes well. No health reactions have been associated with Paulownia, which has no noticeable odour. It is a fast-growing plantation timber which is not an endangered or threatened species. Among the absolute lightest woods available, it is also one of the most stable woods with regard to humidity and has very low movement in service. Paulownia is prized in Asia and used for furniture, boxes, musical instruments (electric guitar bodies), clogs, carvings, shoji screens and other small specialty items. More recently Paulownia has become known as the best wood for shaped timber surfboards.
Pivot Hinge	Pivot hinged shutters with more than 1 panel will be supplied with a D-Mould/Astragal Stile (Rabbit stiles are not available with Pivot Hinges). Please specify the D location clearly in the Layout Code. If a D Mould is not required, please clearly note this in the

	Special Comments. Magnets & L shaped catches are included. Light Stop is an option, please specify in the Left/Right/Top/Bottom drop downs on the order form. D Moulds will be notched out at the top and bottom to accommodate any adjacent Pivot Hinges.
Rabbit Stile - Changing Default Side	Right hand panels always open first as default, unless otherwise requested in the Special Comments. There are two options to request the left-hand panel to open first where required. Firstly, if all pairs of opening panels in the item are to be left first, use the Standard Special Comments drop down "Left Panel Open First". If a mix of left and right panels are to open first, specify panels by assigning panel numbers from the left to right and make a request in Special Comments corresponding to the related Line Item on the order form. For example, "Panel 2 and 3 to open first".
Rail Depth (Height)	Top & Bottom Rail heights are variable depending on the height of the panel and the number of blades required. Panels can be ordered with "Maximum Amount of Blades" or "Smallest Possible Top and Bottom Rails" requested in the Special Comments. However the Top and Bottom Rails must be made within factory determined specifications so it does not affect the integrity and overall strength of the panel. Smaller rails contribute to the possibility that panels may need to be lifted onto and off their frames. Top and Bottom Rails will not be made with a height of less than 80mm without a warranty waiver.
Reveal Depth	The depth of the reveal, where the shutter or frame will be mounted, needs to be measured, to ensure no mullions, handles or key locks etc. will interfere with the operation of the blades when open. With Hidden tilt rods, measured from the front edge of the frame, TIMBER eco 89mm blades need 62mm, 63mm blades need 50mm and 114mm blades need 75mm clear depth. This depth will then determine the framing options available to suit the requested blades. All default Recess fit frames (L and Z) are 50mm deep. Recess Fit L frames are positioned flush to the front edge of the reveal, whereas Z frames are positioned partially in the reveal and partially into the room as they wrap over an architrave or the wall.
Reveal Fit Frames	Frames are useful for most reveal fit applications, as they enable the shutter panel to be installed square in the frame. The overlap on a Z frame will cover gaps. Alternatively, any uneven gaps around an L frame can be filled with a flexible filler, such as No More Gaps.
Ring Pull	Ring Pulls will assist gathering Bifold panels to stack them. Usually fitted one per pair of panels in the centre of the stile, default is opposite the midrail. Use the Order Form Comments section to order this option. Surcharge applies
Shaped Shutters Framing	The use of framing on all Shaped Shutters is highly recommended. Z frame is best for recess fit as most shapes are square stopped and will have some variances. FF L Frame is ideal for Face Fit.
Shaped Shutters Ordering	Drawings for straight line shapes and Templates for curved shapes must be supplied as supporting documentation to the Standard Order Form. "Shaped Shutter – see attached diagram" must be selected in the window type column on the order form. Shaped Shutters require a longer lead time, due to the specialised processes involved, the date of order begins from when the factory drawings have been approved (by the customer) and confirmed by the factory.
Side by Side	Side by Side is a term that, when used in Special Comments, advises the shutter designer that several items are in the same room. Some items of a similar drop may be made with different blade numbers and rail sizes as they fall either side of a guideline. To prevent this, please advise in the notes section if any items are "side by side". If they are side by side but have significantly different opening heights, note if they line up at the top or bottom.

Sliding L Brackets	Default sizes supplied (unless otherwise specified): 95mm Bracket – supplied with 100mm Headboard 135mm Bracket – supplied with 140mm Headboard 175mm Bracket – supplied with 180mm or 220mm Headboard
Sliding Bottom Guide	Floor Guides are only recommended for single (not Combo) TIMBER eco panels. They are fitted where the panels overlap. Bottom Track is highly recommended as tracks with spring loaded guides give stability to both ends of the panel, reducing wear on components and delivering smooth operation.
Sliding Fascia	For all Sliding Panels a Fascia will be supplied. IN arrangements are supplied without returns unless returns are requested in Special Comments. Please specify length of return based on the longest side (external mitre). OUT arrangements are supplied with returns to fit the head board depth. Please note if fitting to an architrave, you may require returns that are longer by the depth of the architrave. Please request this in Special Comments.
Sliding Frame Depths	2 Tracks of panels with 63mm blades will pass with the blades open on a 140mm Headboard, if fitted to the wall without architrave; with an architrave that is less than 50mm wide and no more than 12mm deep; or directly onto an existing architrave. 2 Tracks of panels with 89mm blades will pass with the blades open on a 180mm Headboard if fitted to the wall without architrave; with an architrave that is less than 50mm wide and no more than 12mm deep; or directly onto an existing architrave.
Sliding Layout Codes	When ordering the Panel Quantity must match the Layout Code e.g. 2 Panels = BF; 2 Combo Panels (4 panels joined in pairs) = BBFF and Panel QTY is 2; 4 sliding panels centre opening is BFFB with Panel QTY 4.
Sliding Open or Closed	There are two sliding options with Sliding Panels; Sliding OPEN is when the blades will bypass when fully open. This the recommended option for most situations. Sliding CLOSED is when the blades must be closed prior to sliding one panel in front of the other. This is recommended for three or more track arrangements. Sliding CLOSED panels have their blades closed when stacked, therefore preventing light and view through the stacked panels, which can darken the room unintentionally. There is a risk of damage, if the panels are slid without first closing the blades, therefore sliding closed is not recommended in rental accommodation, commercial, or children’s rooms.
Sliding Panel Frames	Headboard, Sideboards and Bottom Boards in each opening are supplied the same depth as each other. There are 4 standard board depths to select from, depending upon if the arrangement is sliding open or closed; blade size; the number of tracks; and any protrusions in the opening, including an architrave (see configuration chart). The headboard and track will not exceed 4200mm in length, sizes ordered over 4200mm will be in two sections. Stains can be supplied up to 4200mm however there will be a join (made pre-finishing) that may be visible on boards over 2500mm. This join will be positioned in consideration of the arrangement. For example, a 4000mm opening with BFFB, the Fascia will be joined at 2000mm. Side Frames/Boards are recommended on all Sliding Panels. Please select “YES” in the “Left & Right” Framing Columns on the order form. Side Frames/Boards will be the same size as the Top Frames/Headboard. When Side Frames/ Boards are selected a large Light Block will be supplied for the face edge of the SB, along with small Mounting Blocks. If NO Side Frames/Boards are selected, but a Light Block is required on each side, please select “Light Stop” in the “Left & Right” Framing Columns on the order form. Light Blocks for the overlap between the panels are supplied with all Sliding panels when ‘Sliding Open’ is requested on the order form. To reduce the light gap when the panels meet, the size of the Light Blocks will vary depending on the blade size chosen.

Sliding Track Colours	White toned panels are supplied with White bottom tracks. Stained panels with Brown bottom tracks, except Riva, Grey and Black toned panels will be supplied with Silver bottom tracks. Variations should be requested in the Notes area on the order form.
T Posts	<p>If T Post(s) are to be situated so that the panels are all equal widths, use the drop down “All Even Panels” in one of the Standard Special Comments columns.</p> <p>For unequal width panels, specify where you require the T Post to be situated, measuring from the left-hand side of the opening to the centre of each T Post, in the T Post columns on the order form.</p> <p>T posts are most commonly placed in front of a window mullion. Exceptions can be when the window catch may be rendered difficult to access behind a T Post. In this case, position the T post elsewhere, or consider using a frame that offers more clearance. T Posts can also be used horizontally to split panels in an opening instead of using a mid-rail. Please see Horizontal T Posts.</p>
Tall Panels	Any shutter over 2500mm high will require two mid rails, however only one of these mid rails can be specified as “Critical Mid Rail” – please specify which Mid Rail is Critical (if any) on the order form, in the Special Comments.
Templates Available	SEE Bay Window; Corner Window; Box Window; Horizontal T Post; or Door Cut Out in this glossary for a list of Templates available
Water Proof	TIMBER eco shutters are not water proof. Should TIMBER eco shutters be caught in a rain shower and become wet, all water must be dried as soon as possible. A hair-drier on a cold setting can be used to blow water out from between the stile and blades and a soft towel used to ensure no water is left between and around the frame and panel. Any resulting water damage is not covered under warranty.

16. Shutter Range & Mounting Methods

Reference Charts

Please refer to the following pages.

Material		Timber
Shutter Range		 <p>Timber Eco™</p>
Selling Features		<p>Largest Range Of Colours Painted, Stained & Laminated Finishes Wide Panels Broad Range Of Options Genuine Timber Custom Colours Available On Request Special Bi-Fold Features, Concealed Hinges, Pull Rings & Flush Bolts Optional Laminated Coating To Provide Extra Protection</p>
Material		
Material		Paulownia Timber
Advantages		
Fire Retardant		
Termite Proof		
Insulative Properties <i>Keeps Homes Both Cooler In Summer & Warmer In Winter</i>		✓
Repels Moisture		
High Tensile Coatings <i>Will Not Crack Or Peel</i>		
Colour	Finish	Colour Options
Antique White	Painted	✓
Eggshell		✓
Grey		✓
Jasper		✓
Light Grey		✓
Pure White		✓
Slate		✓
White		✓
Bright White		✓
Classic White		✓
Snow White		✓
Super White		✓
Vanilla		✓
Ceylon		✓
Earl Grey		✓
French White		✓
Infinite White		✓
Polar White		✓
Quiet White		✓
Snowy Mountains White		✓
Custom Paint ¹	✓	
Black Walnut	Stained	✓
Cedar Medium		✓
Maple		✓
Riva		✓
Walnut		✓
Barca Walnut	Laminated	✓
Royal Walnut		✓
Colombia Walnut		✓
Shadow Chasing Walnut		✓
Blade Types		
Blade Shape		Elliptical
Size		Blade Sizes
63mm ²		✓
89mm		✓
114mm ²		✓
Tiltrod Types		
Centre ²		✓
Hidden		✓
Off-Set ²		✓
Rack & Pinion ²		✓
Panel Heights		
Minimum Panel Height		350mm
Maximum Panel Height		3000mm
Midrail Required Over		1800mm
Panel Widths		
Minimum Panel Width		250mm
Standard Panel Width (Maximum)		950mm
Over Standard Panel Width For 63mm Blades (Maximum) <i>With Hinged, Fixed, Sliding Mounting Options Only</i>		N/A
Over Standard Panel Width For 89mm Blades (Maximum) <i>With Hinged, Fixed, Sliding Mounting Options Only</i>		N/A
Maximum Panel Widths - By Mounting Method		
Maximum Panel Widths - By Mounting Method		<i>Please Refer Next Page</i>
Rail Profiles & Hinge Sizes		
Top & Bottom Rail		Standard Profile
Hinge Size		Standard 77mm
Special Options Available		
Shaped Shutters ³		✓
Door Cutouts		✓
Bay Windows		✓
Corner Windows		✓
Fluffy Strip Stile		✗
Pivot Hinged Panels ⁴		✓
Lockable		✓
Motorised Option		✓
Suitable For Wet Areas		✗
Notes:		<p>¹ Custom Paint Surcharge applies. ² Not available in the Timber Laminated Shutter Range. ³ Shaped Arch, Shaped Round & Shaped Sunburst are not available in the Timber Laminated Shutter Range. ⁴ Pivot Hinges are only available in White & Stainless Steel. Larger Panels may sometimes require lifting in to the frame.</p>

Shutter Mounting Methods Reference Chart

Options		Hinged Panels	Double Hinged Panels	Fixed Removable Panels	Bi-Fold Panels	Sliding Panels
Recommended Applications For Use		Windows	Windows	Fixed Glass Windows Wall Cut-Outs	Room Dividers Doorways	Room Dividers Doorways
Allowances						
Recess Fit (IN)		✓	✓	✓	✓	✓
Face Fit (OUT)		✓	✓		✓	✓
Product		Panel Widths				
Minimum Panel Width	Timber Eco/Laminated	250mm	250mm	250mm	250mm	250mm
Maximum Panel Width	Timber Eco/Laminated	950mm	600mm/1200mm Over 2 Panels	950mm	700mm	950mm
Maximum Panel Width - Combo Panels	Timber Eco/Laminated	N/A	N/A	N/A	N/A	1500mm
		Panel Heights				
Minimum Panel Height	Timber Eco/Laminated	350mm	350mm	350mm	350mm	350mm
Maximum Panel Height	Timber Eco/Laminated	3000mm	N/A	3000mm	3000mm	3000mm
Framing Options						
L Frames (In/OUT)	Timber Eco/Laminated	✓	✓	✓ (With Magnets & Catches)		
Z Frames (IN)		✓	✓	✓ (With Magnets & Catches)		
T Post (Hinging Extra Panels)		✓	✓	✓ (With Magnets & Catches)		
Top & Bottom U Channels				✓		
Left & Right Light Stops		Optional		Optional		✓
Top Headboard (100mm) With Track					✓	✓
Top Headboard (100mm, 140mm, 180mm, 220mm) With Track						✓
Top Fascia					✓	✓
Sideboards (100mm)					✓	✓ (To Match Headboard Size)
Large Light Block					✓	✓
Mounting Block					✓	✓
Bottom Track/Track On Or In-Board					✓	✓
Floor Guide					✓ ³	
Special Options Available						
Shaped Shutters ²	✓ ¹	✗	✓	✗	✗	
Door Cutouts	✓	✓	✓	✓	✓	
Bay Windows (135° Bay Post)	✓	✓	✗	✗	✗	
Corner Windows (90° Corner Post)	✓	✓	✗	✗	✗	
Layout Code Examples						
Layout Code Example	LR LTLR RTRTR	LL RR LLRR	No Layout Codes Required	LL RR LLRR	BFFB BMFFMB	
Layout Code Explanation		Two panels hinged together, with no top or bottom tracking. Maximum two panels hinged together. Combined panel width must be less than panel height.	N/A	Can only have even panels (i.e. 2/4/6/8 etc)	Either slide with blades open or closed, based on headboard sizes chosen. Combo Panels - 2 panels hinged together to slide as one.	
Notes:	¹ Must hinge from the longest side of the panel. ² Shaped Arch, Shaped Round & Shaped Sunburst are not available in the Timber Laminated Shutter Range. ³ Not available with the Bottom Wheel Sliding System					